

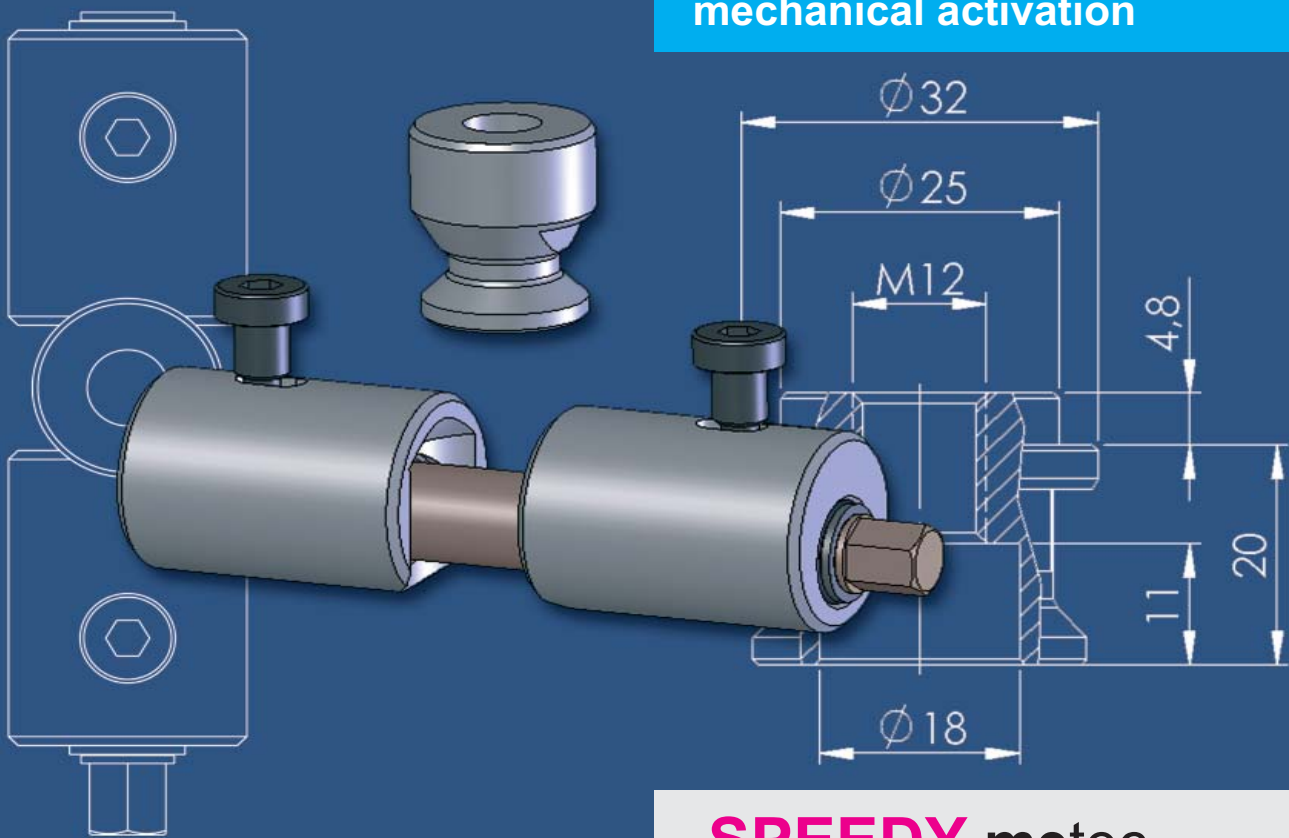

**STARK**

...the solid mechanical zero point mounting system

Reliable clamping with  
mechanical activation



**SPEEDY** metec

Zero point mounting system

## SPEEDY metec – two robust mechanical zero point mounting systems with high retention force, 12kN-20kN

### metec 12 - 20 mechanical zero point mounting system

#### Automation is not always required!

SPEEDY metec is a solid, mechanical zero point mounting system that enables straightforward and economical zero point mounting solutions.

- Just approx. 2 rotations and the workpiece is mounted
- Mount workpiece with vices or other chucks
- Direct mounting of workpiece
- Directly mount to your own workpiece receptacles such as brackets, cubes or plates



Machine vice with SPEEDY metec, with a retention force of up to 20kN per mounting position, ideal for 5-sided processing.

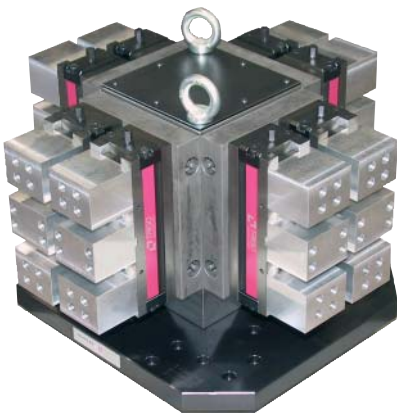

Practical installation: machine vices with SPEEDY metec, mounted to a machine bracket.

#### Save setup times and gain flexibility with the SPPEEDY metec

- Straightforward and robust construction for a long service life
- No lateral forces on the insertion bolts
- Two sizes are available with retention forces of 12 kN and 20 kN respectively
- Easy handling
- No additional media required (compressed air, hydraulic oils)
- High flexibility due to various insertion bolts
- Low acquisition costs, fast amortisation
- Universally applicable as construction element
- Low setup times due to short mounting times
- Repeatability precision during palette changing of <0,01mm possible

## SPEEDY metec 12

### clamp mechanically, release mechanically

**metec 12** mechanical zero point mounting system

**Order number: 2000 001**



Retention force: 12kN  
 Torque  
 Spindle: 60Nm  
 Activation: 2,5 rotations  
 Thickness of  
 the Plate: min. 40mm

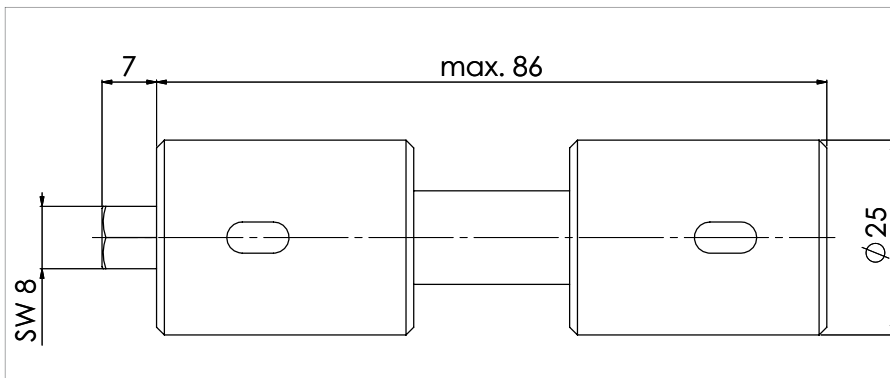

Actual dimensions:  
[www.stark-inc.at/Admin/extranet/login\\_extranet.php](http://www.stark-inc.at/Admin/extranet/login_extranet.php)  
 Data sheet number D034

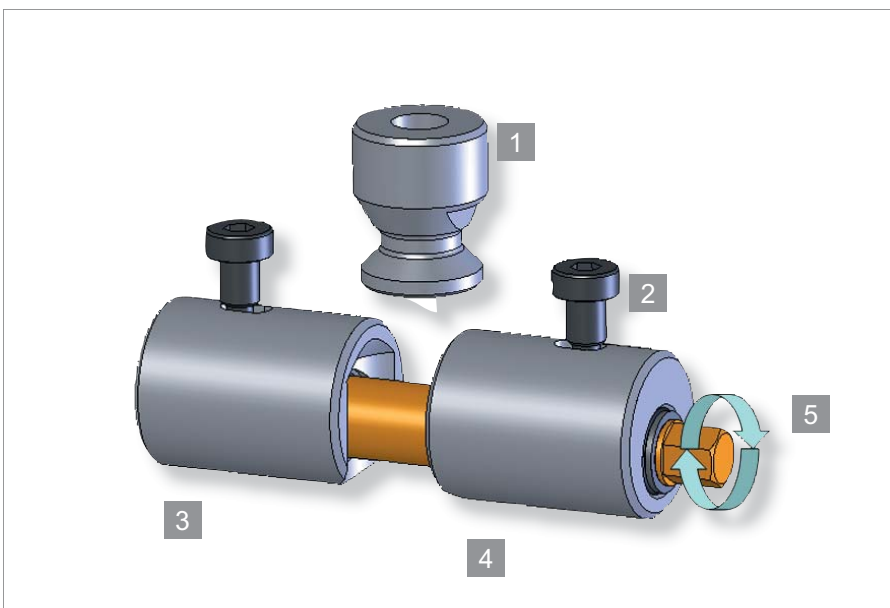

- 1 Insertion nipple
- 2 Locking piston
- 3 Linchpin, left
- 4 Linchpin, right
- 5 SW8/13 for activation

## SPEEDY metec 12

### Insertion nipple - technical data

#### metec 12 Insertion nipple with zero point

**Order number: 2000 009**

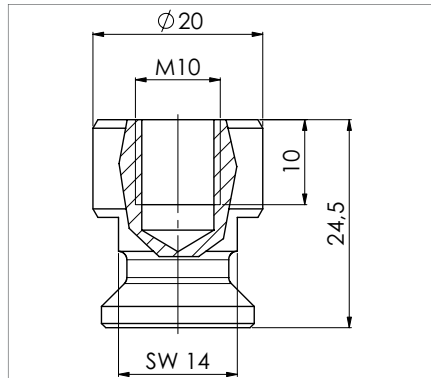

Mounting screws: M10 / 10.9

Torque: 67Nm

Actual dimensions:

[www.stark-inc.at/Admin/extranet/login\\_extranet.php](http://www.stark-inc.at/Admin/extranet/login_extranet.php)

Data sheet number D035

#### metec 12 Insertion nipple with compensation

**Order number: 2000 010**

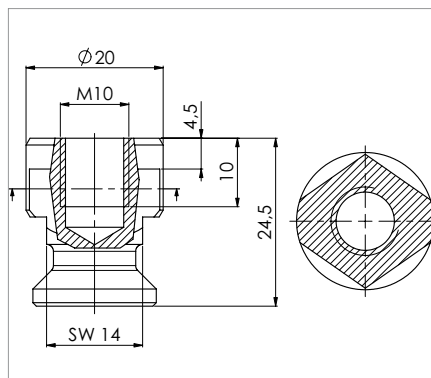

Mounting screws: M10 / 10.9

Torque: 67Nm

Actual dimensions:

[www.stark-inc.at/Admin/extranet/login\\_extranet.php](http://www.stark-inc.at/Admin/extranet/login_extranet.php)

Data sheet number D035

#### metec 12 Insertion nipple without centering

**Order number: 2000 011**

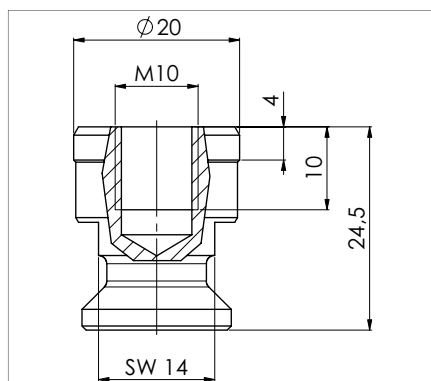

Mounting screws: M10 / 10.9

Torque: 67Nm

Actual dimensions:

[www.stark-inc.at/Admin/extranet/login\\_extranet.php](http://www.stark-inc.at/Admin/extranet/login_extranet.php)

Data sheet number D035

## SPEEDY metec 20

### clamp mechanically, release mechanically

**metec 20** mechanical zero point mounting system

**Order number: 2000 101**

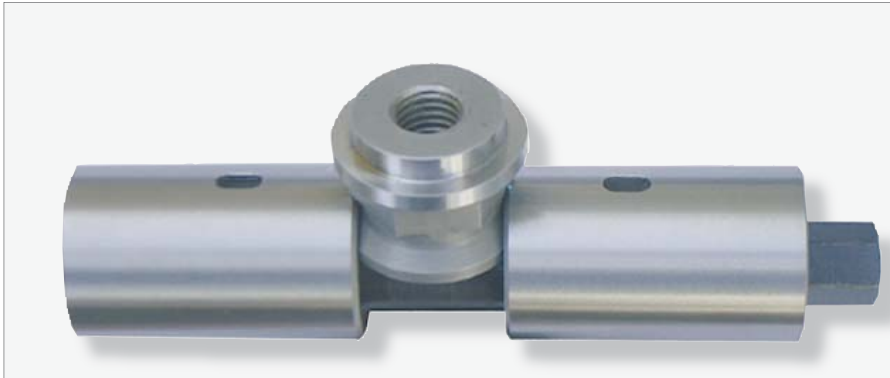

Retention force: 20kN  
 Torque  
 Spindle: 80Nm  
 Activation: 2,5 rotations  
 Thickness of  
 the Plate: min. 45mm

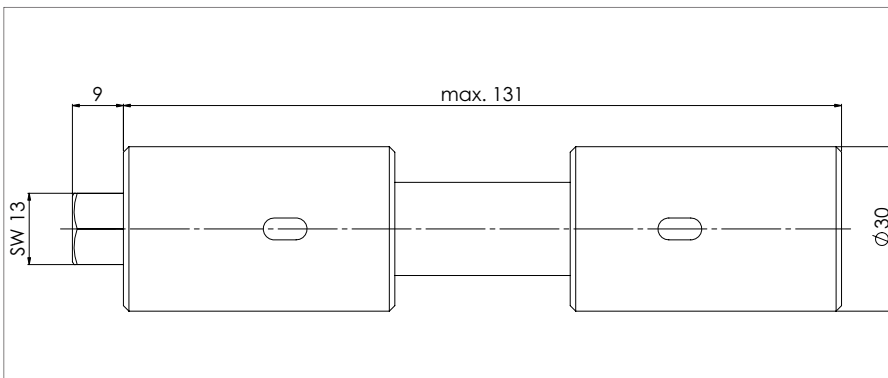

Actual dimensions:  
[www.stark-inc.at/Admin/extranet/login\\_extranet.php](http://www.stark-inc.at/Admin/extranet/login_extranet.php)  
 Data sheet number D045

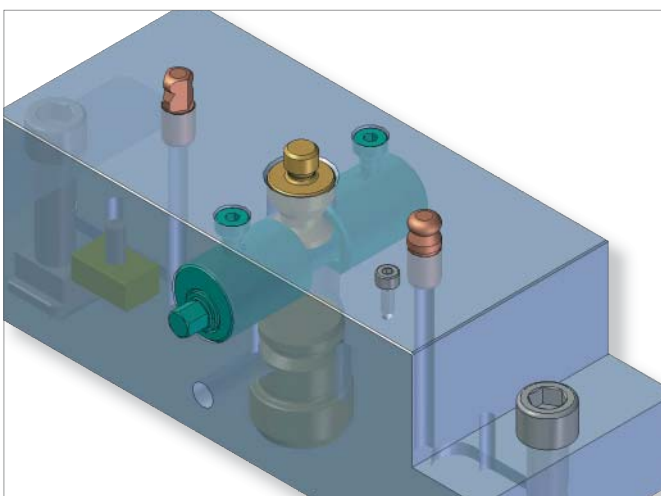

HILMA Quintus-quick clamping block with **SPEEDY metec**

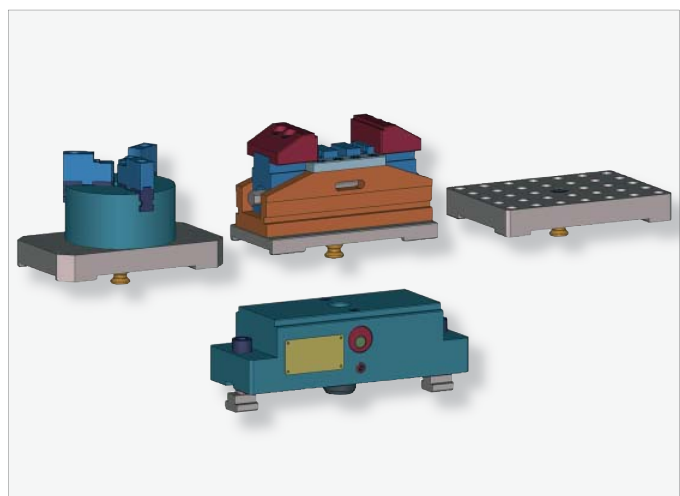

Variations and applications for **SPEEDY metec** with a retention force of 20kN per mounting positions, ideal for quick, easy setups.

## SPEEDY metec 20

### Insertion nipple - technical data

#### metec 20 Insertion nipple with zero point

**Order number: 2000 109**

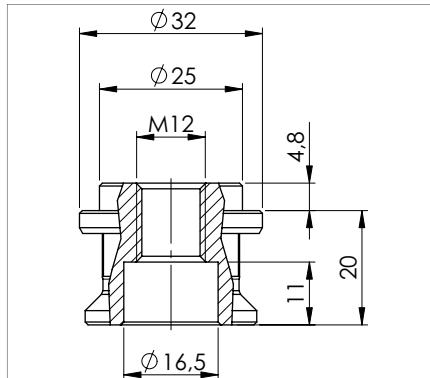

Mounting screws:

Bolted from below M10 / 10.9  
Bolted from the top M12 / 10.9

Torque: M10 65Nm  
M12 117Nm

Actual dimensions:

[www.stark-inc.at/Admin/extranet/login\\_extranet.php](http://www.stark-inc.at/Admin/extranet/login_extranet.php)

Data sheet number D029

#### metec 20 Insertion nipple with compensation

**Order number: 2000 110**

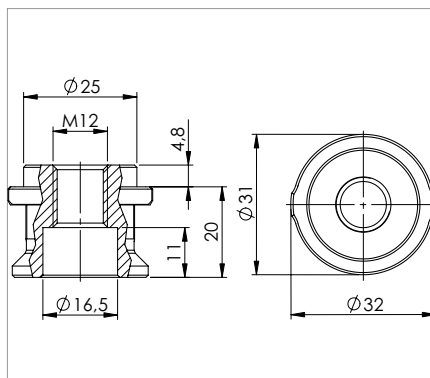

Mounting screws:

Bolted from below M10 / 10.9  
Bolted from the top M12 / 10.9

Torque: M10 65Nm  
M12 117Nm

Actual dimensions:

[www.stark-inc.at/Admin/extranet/login\\_extranet.php](http://www.stark-inc.at/Admin/extranet/login_extranet.php)

Data sheet number D029

#### metec 20 Insertion nipple without centering

**Order number: 2000 111**

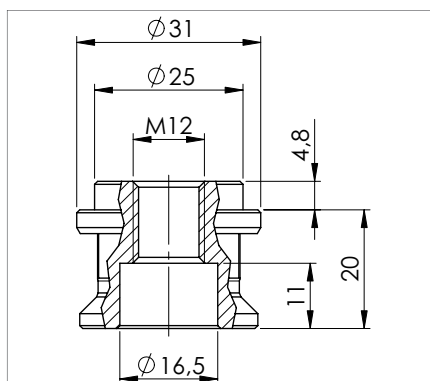

Mounting screws:

Bolted from below M10 / 10.9  
Bolted from the top M12 / 10.9

Torque: M10 65Nm  
M12 117Nm

Actual dimensions:

[www.stark-inc.at/Admin/extranet/login\\_extranet.php](http://www.stark-inc.at/Admin/extranet/login_extranet.php)

Data sheet number D029

... speed for your manufacturing with,

**SPEEDY classic**

**SPEEDY metec**

**SPEEDY airtec**

**SPEEDY hydratec**

Do you need a solution for your  
zero point mounting task?

Do you want to reduce setup times and gain flexibility?

Trust our decades of experience and thousands of satisfied  
STARK customers.

Up-to-date information and catalogues can be found on our  
website [www.stark-inc.com](http://www.stark-inc.com)

All rights reserved, status September 06



Stark Spannsysteme GmbH  
Kommingerstraße 48  
A-6840 Götzis  
Tel.: +43 (0) 55 23 / 6 47 39-0  
Fax: +43 (0) 55 23 / 6 47 39-7  
E-mail: [verkauf@stark-inc.com](mailto:verkauf@stark-inc.com)  
[www.stark-inc.com](http://www.stark-inc.com)