

Retractable nipple

The retractable nipples can be used with SPEEDY Sweeper 2000 and SPEEDY hydratec.

Retractable nipple with zero point



Properties:

Retractable nipple with zero point.

Areas of application:

Palettes, machine vices, chucks, jigs, workpieces-direct clamping.

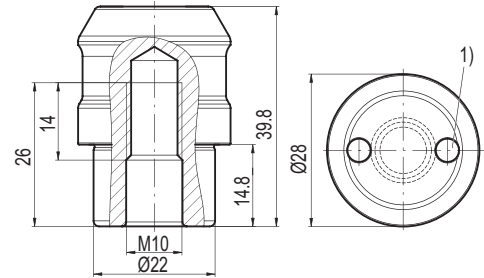

1) Use retractable nipple key to tighten. Tightening torque 75 Nm.

Order no.	Designation	Weight
804 490	Retractable nipple with zero point	0,13 kg

Retractable nipple with compensation



Properties:

Retractable nipple with compensation in one axis (sword shape).

Areas of application:

Palettes, machine vices, chucks, jigs, workpieces-direct clamping.

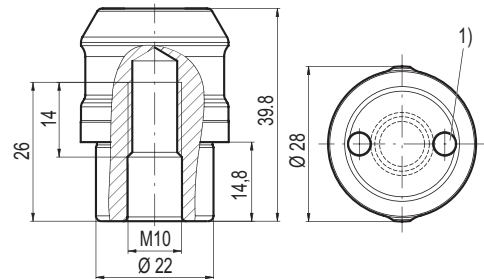

1) Use retractable nipple key to tighten. Tightening torque 75 Nm.

Order no.	Designation	Weight
804 495	Retractable nipple with compensation	0,13 kg

Retractable nipple without centering



Properties:

Retractable nipple with compensation in all axis.

Areas of application:

Palettes, machine vices, chucks, jigs, workpieces-direct clamping.

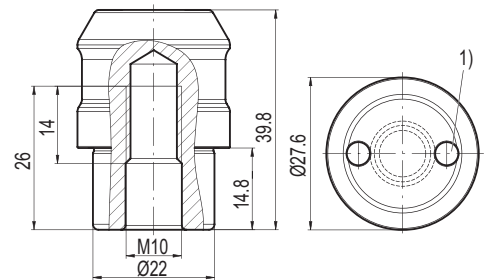

1) Use retractable nipple key to tighten. Tightening torque 75 Nm.

Order no.	Designation	Weight
804 485	Retractable nipple without centering	0,13 kg

Draw in nipple spanner

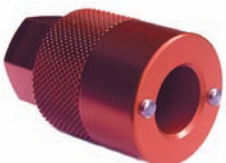

Tightening torque:
M8 = 20 Nm, M10 = 45 Nm

Areas of application:

Attachment of the retractable nipple.

Order no.	Designation
804 247	Draw in nipple spanner, SW 22
804 257	Socket 3/8", SW22 for retractable nipple

Accessories

Distancer

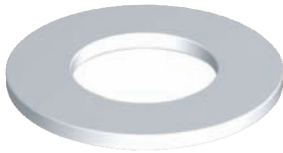

Properties:

Distancer with seal.

Areas of application:

Distancer for height compensation for SPEEDY Sweeper 2000 with central locking and mount.

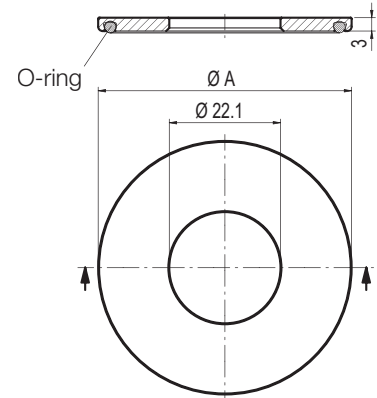

Order no.	Designation	Ø A	Weight
804 283	Distancer for SPEEDY Sweeper 2000	42 mm	0,02 kg
804 289	Distancer for SPEEDY Sweeper 2000 and SPEEDY hydratec	57 mm	0,03 kg

Washer

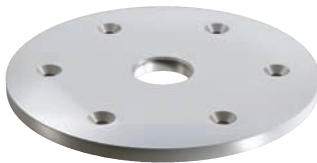

Properties:

Hardened washer

Areas of application:

Washer for SPEEDY Sweeper 2000 and SPEEDY hydratec. To use with non-hardened surfaces

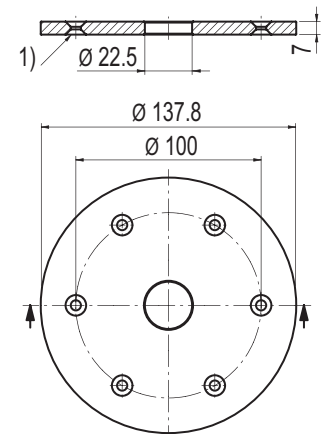

1) Recess for M5 - screw DIN 7991

Order no.	Designation	Weight
804 284	Washer for SPEEDY Sweeper 2000 and SPEEDY hydratec	0,8 kg

Sample application

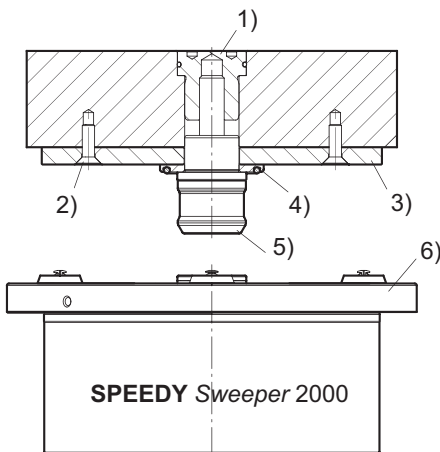

SPEEDY Sweeper 2000 for permanent automatic production. Retractable nipple with distancer and hardened washer.

Advantages:

- Safe and reliable surface blow off
- Nearly no wear
- Surface control available with differential pressure, blocking air

- 1) Nipple mount
- 2) Countersunk head screw DIN 7991
- 3) Hardened surface
- 4) Distancer
- 5) Retractable nipple
- 6) SPEEDY Sweeper 2000
- 7) SPEEDY hydratec

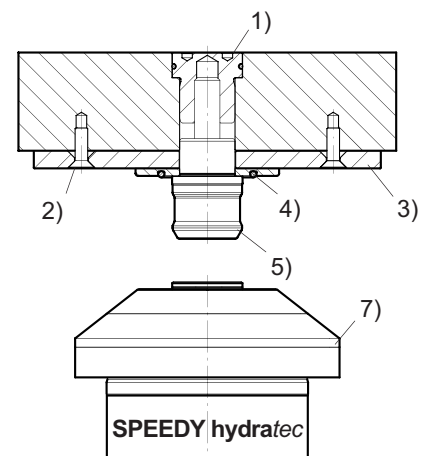

To combine SPEEDY Sweeper 2000 with the SPEEDY hydratec, use distancer, pos. 4, order no. 804 289.

Accessories

Nipple mount version D



Properties:

Nipple mount with O-ring.

Areas of application:

Equipment palettes, handling palettes, adapter palettes.

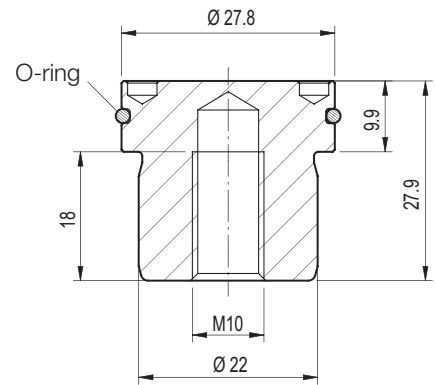

Order no.	Designation	Weight
809 125	Nipple mount version D	0,09 kg

Nipple mount, version E



Properties:

Hardened screw retainer.

Areas of application:

Equipment palettes, handling palettes, adapter palettes.

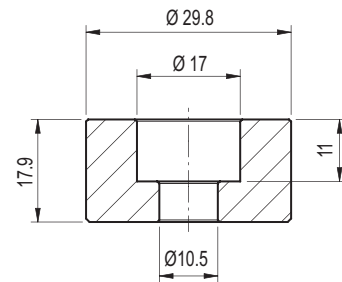

Order no.	Designation	Weight
809 120	Nipple mount, version E	0,07 kg

Versions D and E have the advantage that the fit diameter can be made with high precision on the upper side of the palettes in a single setting up operation.

Mounting versions for retractable nipple

Version A

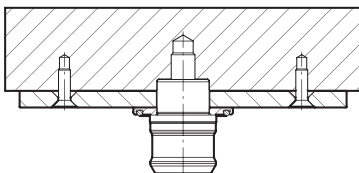

Version B

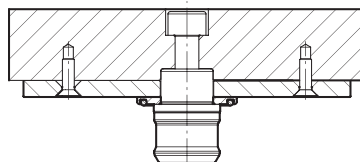

Version D

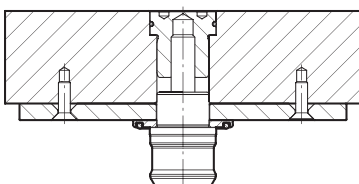

Version E

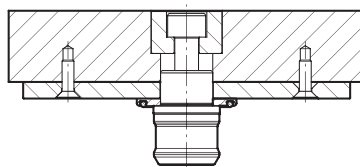

For SPEEDY hydratec versions without distancer the fitting holes must be made 3 mm deeper.