

## Zero point mounting *system 6000*

### SPEEDY hydratec

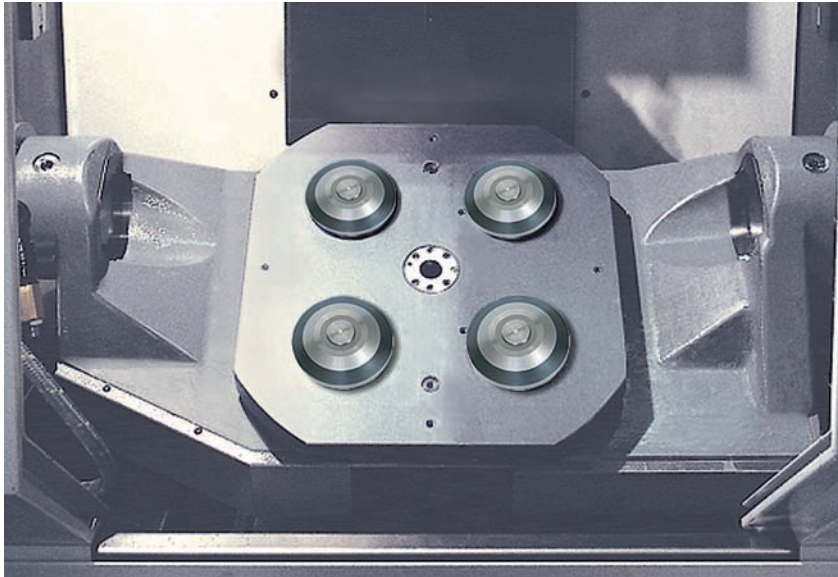

With the SPEEDY hydratec, STARK has developed a hydraulic double action clamping element. If the distancer (order no. 804 289) with the retractable nipple is used the palette can be blocked with SPEEDY *Sweeper 2000* and SPEEDY hydratec. This enables using palettes independently of the different machine setting ups with SPEEDY hydratec or SPEEDY *Sweeper 2000* or moving them from machine to machine. The extremely fast clamping cycles of the SPEEDY hydratec makes it very suitable for applications in automated production with short cycle times.

#### Significant product advantages

- Small in size - enables tight gauges
- extremely fast clamping cycle
- Long service life
- Readjustable clamping force
- Integrated surface control
- Clamping controls and other versions upon request

### SPEEDY hydratec

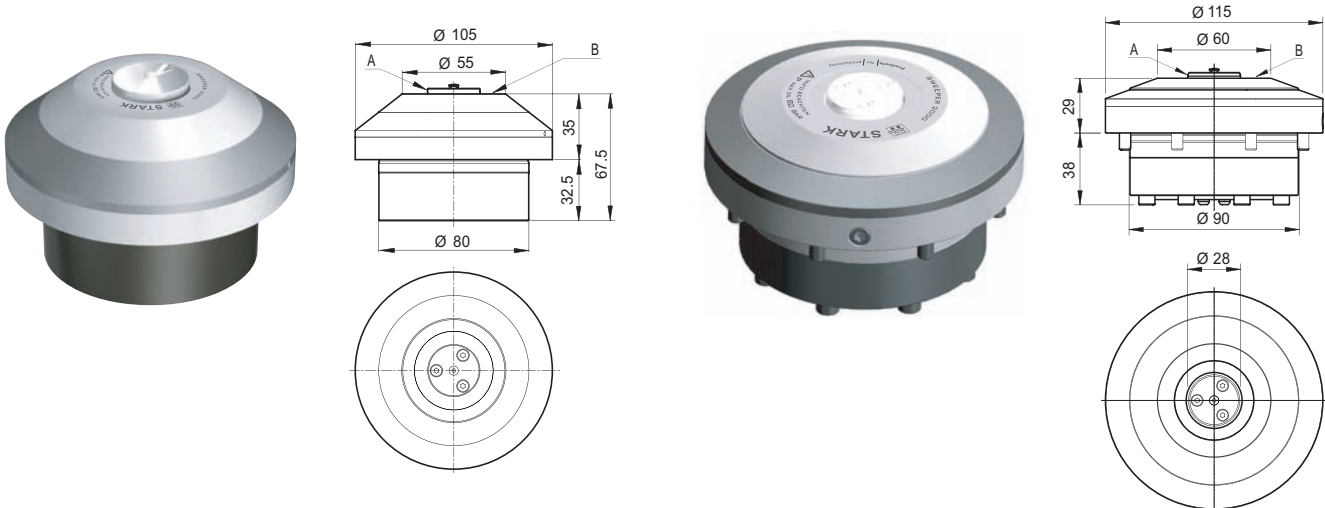

#### Properties:

Hydraulic double action clamping element.  
 Ideal shape for swarf blow off.  
 Positioning is done with the fit diameter (A) of the nipple mount and via the support surface (B).

#### Areas of application:

Automation with short cycle times

| Order no. | Draw in force | System pressure max. | Min. pressure for blow off | Weight  |
|-----------|---------------|----------------------|----------------------------|---------|
| 6000 001  | 20 kN         | 300 bar              | 6 bar                      | 2,60 kg |
| 6000 002  | 20 kN         | 140 bar              | 6 bar                      | 3,50 kg |