

SPEEDY *Sweeper* 2000 – my favorite for automatic production

Time and again, swarf and dirt cause problems when equipping a palette. The SPEEDY *Sweeper* 2000 by STARK has solved this problem. The SPEEDY *Sweeper* 2000 blows all swarf away from the support surfaces. It also closes the center bores and keeps the proven and reliable clamp-mechanism free of dirt.

Swarf free full automatic production – for vertical or horizontal clamping positions



Machine brackets with
SPEEDY
Sweeper 2000
including system- and
clamping controls

In automated systems, reliable system components are essential. While setting up CNC machines, the refuse factor often prohibits safe processing and handling. The central locking provided on the patented STARK clamping device, SPEEDY *Sweeper* 2000 effectively protects the clamping mechanism against refuse. In addition, the mounts and the central locking are cleaned with blow off nozzles making automatic, accurately repeatable zero point mounting possible.

- Upon request, media ducts can be integrated in the SPEEDY *Sweeper* 2000, allowing media to flow through the clamping devices. This technology permits controlling the swivelling mounts or machine vices with the machine control unit.
- The autonomous SPEEDY *Sweeper* multiple coupling can be equipped with up to 8 media ducts with nominal width 5. The ensuing coupling force is bridged by the integrated, double action, hydraulic clamping cylinder.
- As a surface check the air escaping from the blow off nozzles can be controlled by a differential pressure switch.
- The mounting system can also be controlled with an additional camshaft controller or remotely.

Significant product advantages

- Pneumatic self-cleaning system
- Central locking system protects against refuse
- Enables full-automatic machine setting up
- High operational safety during automatic processing
- Special clamping geometry provides no-tilt handling even if the weight distribution is unfavorable.
- 20 kN draw in force, vibration damping permanent draw in system and fail-safe spring activated force.
- Available with integrated media ducts
- Ready for surface and clamp controls
- High clamping cycles
- Modular structure

SPEEDY *Sweeper* clamping devices are modular and can be equipped with a wide range of accessories – to meet your requirements.

- Media ducts
- Clutches
- Mechanical queries
- Blocking air and differential pressure
- Varying clutch travel
- Varying strokes



... ask us.

Zero point mounting system 1000

SPEEDY Sweeper 2000

SPEEDY Sweeper 2000



Properties:

Assembly module with central locking and mount blow off and surface control. Is blocked mechanically and released hydraulically.

Areas of application:

Automated production

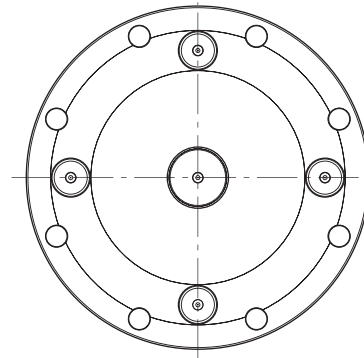
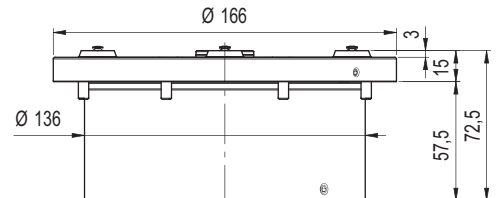

Order no.	Draw in force	Hydraulic release pressure	Min. blow off pressure	Weight
809 100	20 kN	50 bar	6 bar	7,50 kg

Including fixing screws and screw cover caps.

SPEEDY Sweeper 2000 with mechanical query



Properties:

Assembly module with central locking, mount blow off, surface control and cam controller for clamp control. Available with electrical, pneumatic or hydraulic signal processing. The assembly module is mechanically blocked and hydraulically released.

Areas of application:

Automated production

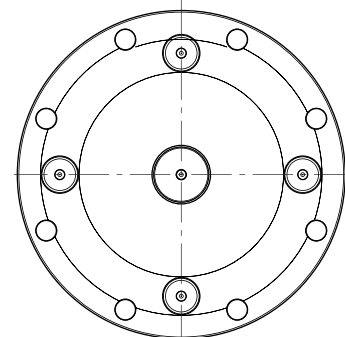
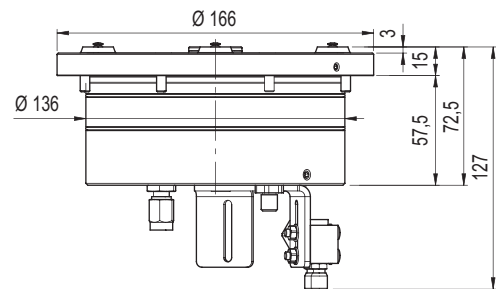

Order no.	Draw in force	Hydraulic release pressure	Min. blow off pressure	Weight
809 107	20 kN	50 bar	6 bar	7,60 kg

Including fixing screws and screw cover caps.

Technical data and other versions of the cam controller upon request.

Zero point mounting system 1000

SPEEDY Sweeper 2000 with media ducts / clutches

SPEEDY Sweeper 2000 with media ducts



Properties:

Assembly module with central locking, mount blow off and 4 media ducts MD (suitable for oil, water, compressed air or vacuum) with NW 4. The assembly module is clamped mechanically and hydraulically released. Cannot be coupled under pressure

Areas of application:

CNC with media ducts on the machine table for hydraulic mounting systems.

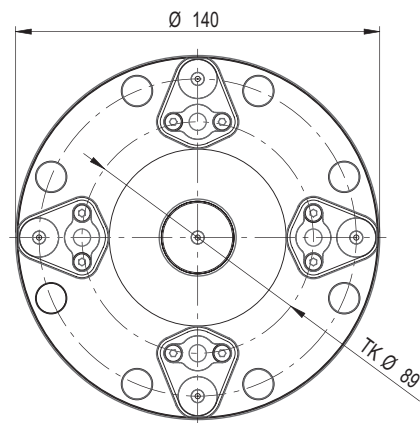
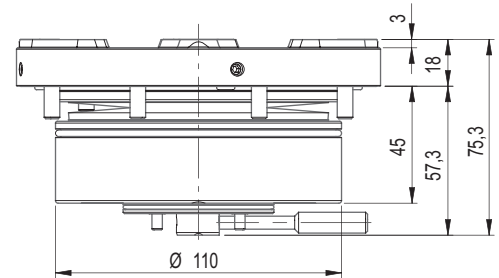

Order no.	Draw in force	Hydraulic release pressure	Min. blow off pressure	MD	NW	Weight
809 108	20 kN	50 bar	6 bar	4*	4	4,40 kg

* Each media duct is designed for a maximum pressure of 200 bar. Including fixing screws and screw cover caps. Technical data and other numbers of media ducts upon request.

Order no.	Designation
704 201	Media ducts NW 4, palette side

For the technical data, refer to the main catalog.

SPEEDY Sweeper 2000 with clutches



Properties:

Assembly module with central locking, mount blow off and 4 clutches, NW 5. The assembly module is clamped mechanically, hydraulically released and can be coupled under pressure.

Areas of application:

CNC with media ducts on the machine table for hydraulic mounting systems.

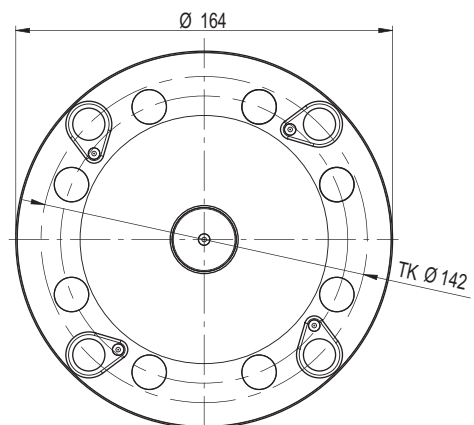
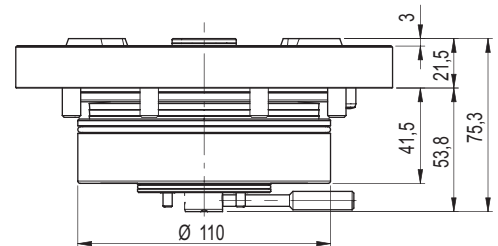

Order no.	Draw in force	Hydraulic release pressure	Min. blow off pressure	Clutches NW 5	Weight
809 109	20 kN	50 bar	6 bar	4*	5,10 kg

* Each clutch is designed for a maximum pressure of 300 bar. Including fixing screws and screw cover caps. Technical data and other number of clutches upon request.

Order no.	Designation
R 0460-691	Clutch nipple NW 5, short version
R 0460-814	Clutch nipple NW 5, long version
R 0460-837	Clutch nipple NW 5, short version with clamping unit

For the technical data, refer to the main catalog.

Multiple coupling

SPEEDY Sweeper 2000

SPEEDY Sweeper 2000 clutch bearing



Properties:

Hydraulic double action clutch bearing with blow off central locking and indexing. The clutches are suitable for oil, water, compressed air and vacuum. The clutches can be coupled under pressure.

Areas of application:

CNC machining centers with clutches on the clamping table, special applications.

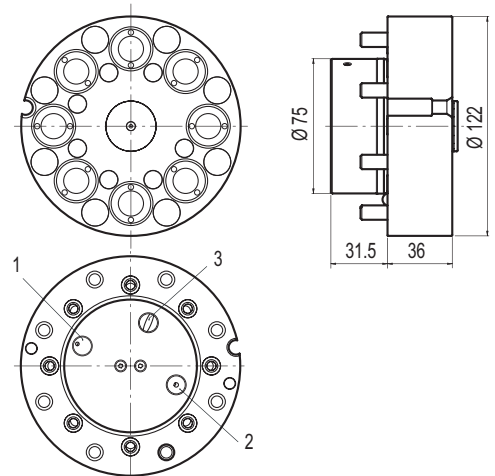

- 1) Oil connection for clamping
- 2) Oil connection for release
- 3) Compressed air connection

Order no.	Clutches NW 5	Draw in force	max. operating pressure	max. pressure bei 4x NW 5	min. pressure for blow off	Radial positioning	Weight
809 200	8	20 kN	300 bar	300 bar	6 bar	± 2 mm	3,40 kg
809 204	4	20 kN	300 bar	300 bar	6 bar	± 2 mm	3,10 kg

Including fixing screws and screw cover caps.

SPEEDY Sweeper 2000 nipple bearings



Properties:

Nipple bearings with clutches (suitable for oil, water, compressed air or vacuum) and indexing. The clutches can be coupled under pressure.

Areas of application:

CNC machining centers with clutches on the clamping table, special applications.

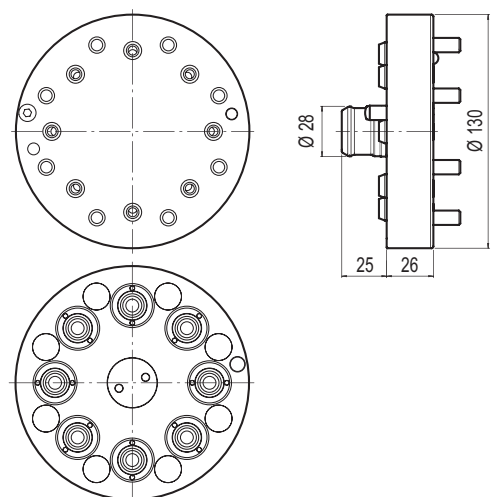

Order no.	Clutches NW 5	Radial positioning	Weight
809 220	8	± 2 mm	2,40 kg
809 224	4	± 2 mm	2,10 kg