

# Sliding clamp single-acting



# HILMA



Hydraulic clamping block

T-slot adapter

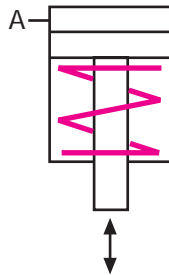

## Applications:

- ▶ on press beds and rams
- ▶ on machines and equipment for clamping and locking when the available space is limited
- ▶ when temperatures may reach 120° C

## Function:

The sliding clamp is manually placed in the T-slot provided in the press ram or bed. The die is clamped on its clamping edge by applying hydraulic pressure to the piston and mechanically unclamped by a spring return. The clamping block may also be fastened directly, without a T-slot adapter (please see product group 2, page 18).

## Special features:

- ▶ Ideal power transmission
- ▶ Compact design
- ▶ Clamping force of between 19 and 78 kN
- ▶ Easy fastening
- ▶ Compensates for large clamping edge tolerances
- ▶ No colliding edges, smooth die positioning
- ▶ Suitable for retrofit
- ▶ No need for die standardisation (width and depth)

## For power units

please see product group 7

## For accessories

please see product group 11

## Recommended accessories:

Angular rotary coupling

Part no. 9280-043

Sliding clamps



Sliding clamps fastened to bed and ram of a double column press. Dies are entered from the front using consoles.



# HILMA



## Sliding clamp single-acting

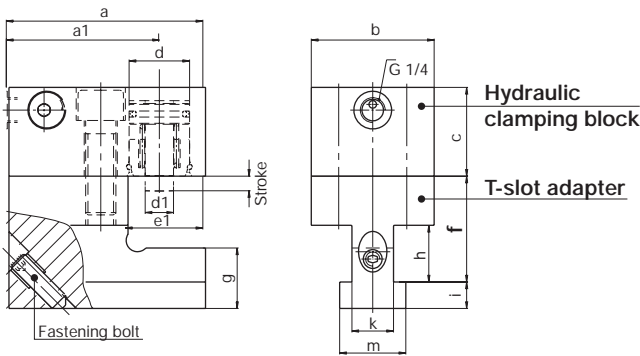

Example of ordering: **8.2202.1850/60**

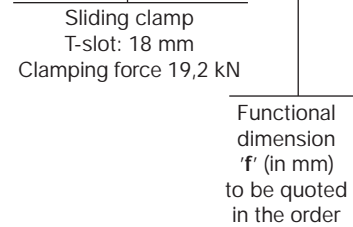

### Sliding clamp complete with T-slot adapter

Part no.	T-slot to DIN 650 (mm)	Clamping force at 400 bar (kN)	Stroke (mm)	Oil consumption (cm <sup>3</sup> )	Dimensions in mm													Weight (kg)
					a	a1	b	c	d	d1	e	e1	g	h	i	k	m	
8.2202.1850	18	19,2	8	4	95	77	65	40	25	15	23	32	24	25	10	18	28	2,9
8.2202.2250	22	19,2	8	4	95	77	65	40	25	15	23	32	32	30	14	22	35	3,2
8.2203.2250	22	32	8	7	104	81	65	47	32	15	28	41	32	30	14	22	35	3,6
8.2204.2250	22	50	8	10	111	85	65	50	40	20	31	48	32	30	14	22	35	3,9
8.2203.2850	28	32	8	7	104	81	65	47	32	15	28	41	42	37	18	28	44	4,2
8.2204.2850	28	50	8	10	111	85	65	50	40	20	31	48	42	37	18	28	44	4,5
8.2205.2850	28	78	12	24	132	99	80	75	50	25	38	60	42	37	18	28	44	7,5

max. operating pressure 400 bar Please consult us if aggressive spray is used

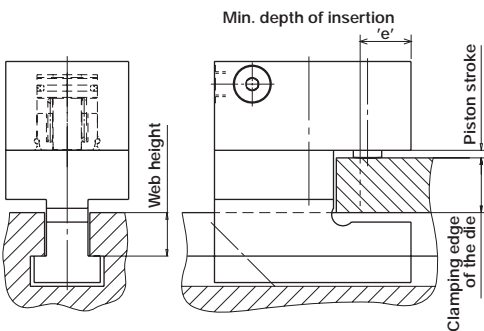

#### Functional dimension 'f':

1/2 stroke  
+ height of die clamping edge  
+ web height of T-slot  
= dimension 'f'

Part no.	Dimension 'f'	
	min.	max.
8.2202.1850	42	90
8.2202.2250	50	106
8.2203.2250	50	106
8.2204.2250	50	106
8.2203.2850	55	106
8.2204.2850	55	112
8.2205.2850	60	117

### Parking station accommodates the clamping element during die change

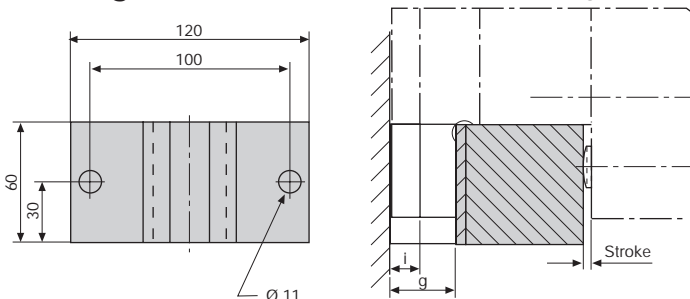

#### Distance 'x':

$$x = f + i - g - 1/2 \text{ stroke}$$

Dimension x to be quoted in the order

For suitable power units, please refer to product group 7, for hydraulic hoses, please refer to product group 11

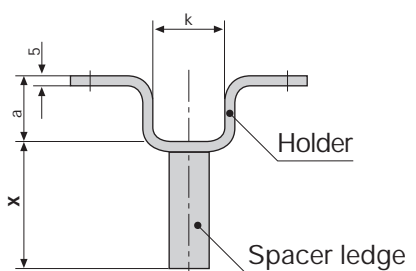

T-slot to DIN 650 (mm)	Parking station complete with holder and spacer ledge Part no.	Holder Part no.	spacer ledge Part no.	a mm	k mm	i mm	g mm
18	8.2754.1850	2754-180	2754-500	25	30	10	24
22	8.2754.2250	2754-220	2754-500	33	37	14	32
28	8.2754.2850	2754-280	2754-500	43	46	18	42

# 3.2200

03/2006

Hilma-Römheld GmbH

Schützenstraße 74 · D-57271 Hilchenbach

Phone +49 (0) 2733 / 281-0 · Fax +49 (0) 2733 / 281-113 · www.hilma.de

Subject to technical modification



## Clamping block - Sliding clamp single-acting with spring return

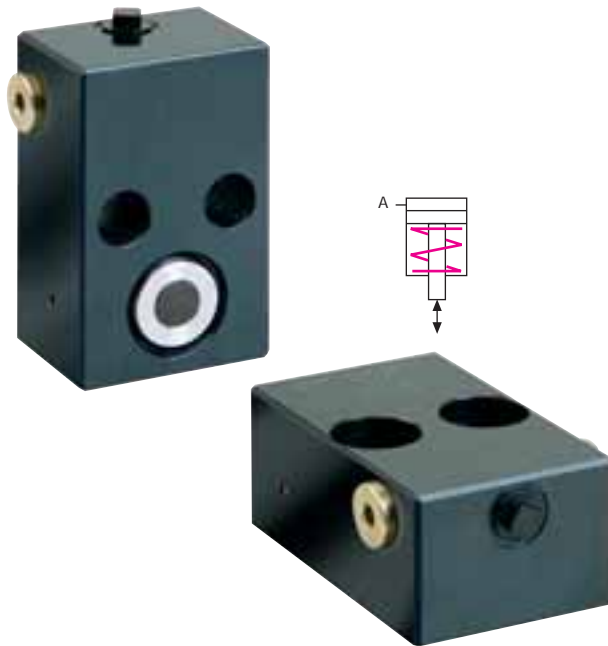

### Applications:

- ▶ on press beds and rams
- ▶ on machines and equipment for clamping and locking
- ▶ when the available space is limited

### Function:

The workpiece is clamped on its clamping edge by applying hydraulic pressure to the piston and mechanically unclamped by a spring return. The clamping block may be fastened by screwing it to stationary spacer ledges or in combination with a T-slot adapter for clamping workpieces in the T-slots of a press bed or ram.

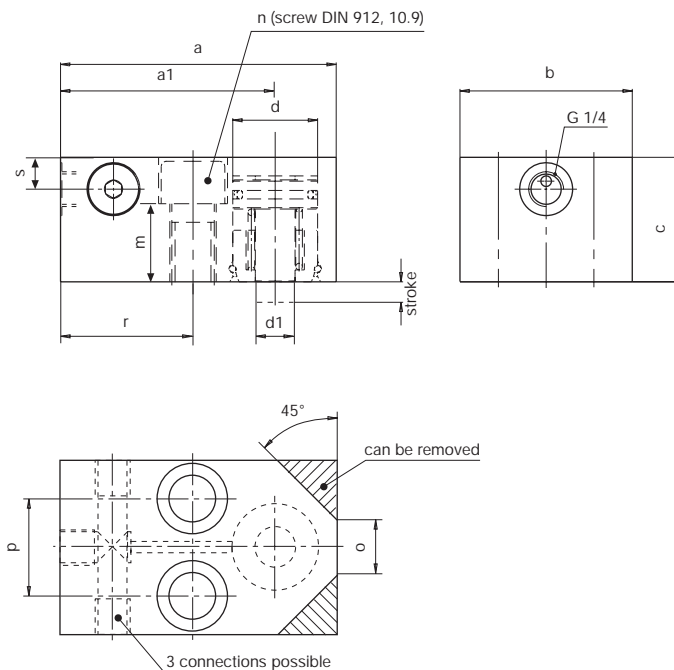

## Hydraulic clamping block without T-slot adapter

Part no.	Clamping force at 400 bar (kN)	Stroke (mm)	Oil consumption (cm <sup>3</sup> )	Dimensions in mm											Weight (kg)	
				a	a1	b	c	d	d1	m	n	o	p	r		s
8.2202.1301	19,2	8	4	95	77	65	40	25	15	24	M16	18	36	50	12,0	1,6
8.2203.1301	32	8	7	104	81	65	47	32	15	29	M16	20	36	50	15,0	2,0
8.2204.1301	50	8	10	111	85	65	50	40	20	32	M16	20	36	50	16,5	2,3
8.2205.1301	78	12	24	132	99	80	75	50	25	53	M20	28	43	57	22,0	4,9

Max. operating pressure: 400 bar.

Fastening screws M16 or M20, DIN 912, 10.9 are not included.



# Angular clamp single-acting



# HILMA



### Applications:

- ▶ on press beds and rams
- ▶ on machines and equipment for clamping and locking
- ▶ when the available space is limited
- ▶ when temperatures may reach 120° C

### Function:

The angular clamp is manually placed in the T-slot provided in press ram or bed. The die is clamped on its clamping edge by applying hydraulic pressure to the piston and mechanically unclamped by a spring return. The clamping block may also be fastened directly, without a T-slot adapter.

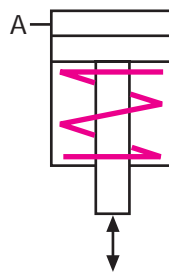

### Special features:

- ▶ Ideal power transmission
- ▶ Compact design
- ▶ Easy fastening
- ▶ Suitable for small clamping edges
- ▶ Suitable for retrofit
- ▶ No need for die standardisation (width and depth)

**For power units**  
please see product group 7  
**For accessories**  
please see product group 11

### Example for application

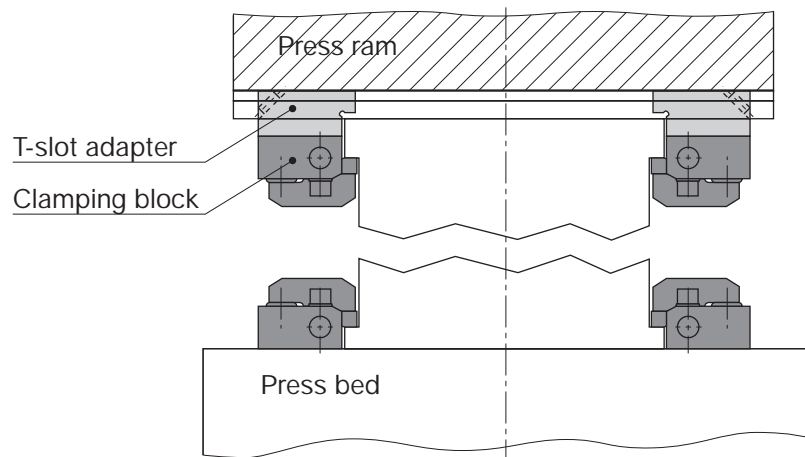



# HILMA



## Angular clamp single-acting

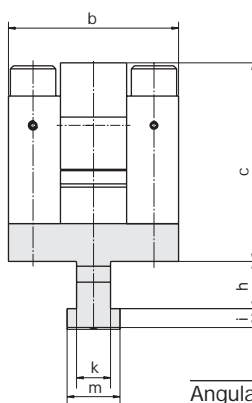
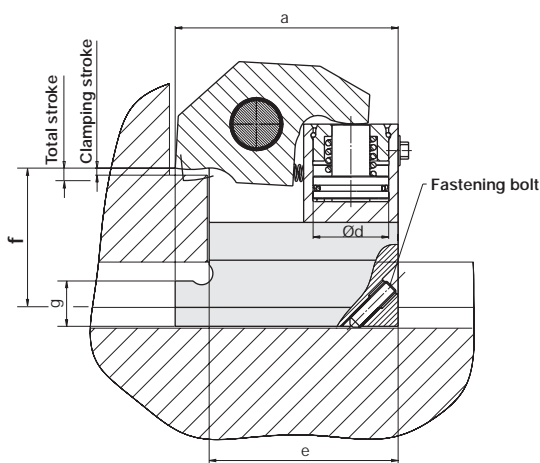

**Example for ordering: 8.2314.2210/110**

Angular clamp  
Clamping force: 66 kN

T-slot: 22 mm

Functional dimension  
'f' (in mm)

to be quoted in the order

### Angular clamp complete with T-slot adapter

Part no.	T-slot to DIN 650 (mm)	Clamping force at 400 bar (kN)	Clamping force (kN) at 100 bar	Total stroke (mm)	Clamping stroke (mm)	Oil consumption (cm <sup>3</sup> )	Dimensions in mm										Weight (kg)		
							a	b	c	d	e	'f' min.	'f' max.	g	h	i		k	m
8.2312.1801	18	40	10	5,5	2,5	6,5	101	75	92	32	85	63	103	24	25	10	18	28	4
8.2312.2201	22	40	10	5,5	2,5	6,5	101	75	90	32	85	67	107	32	31	14	22	35	4,4
8.2312.2801	28	40	10	5,5	2,5	6,5	101	75	90	32	85	73	113	42	37	18	28	44	4,8
8.2314.1810	18	66	16,5	6	3	10	118	90	105	40	100	73	113	24	25	10	18	28	6,4
8.2314.2210	22	66	16,5	6	3	10	118	90	103	40	100	77	127	32	31	14	22	35	6,7
8.2314.2810	28	66	16,5	6	3	10	118	90	103	40	100	83	133	42	37	18	28	44	7,4
8.2315.2810	28	110	27,5	6	3	16	147	120	130	50	125	97	157	41	37	18	28	44	14,2
8.2315.3610	36	110	27,5	6	3	16	147	120	130	50	125	107	167	53	47	23	36	54	15,5

max. operating pressure 400 bar Please consult us if aggressive spray is used

#### Please note:

Further dimensions with other clamping forces and T-slots are available on request. The angular clamp may also be fastened directly, without a T-slot adapter. Position monitoring using laterally installed proximity switches on request.

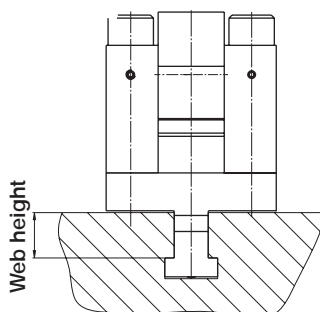
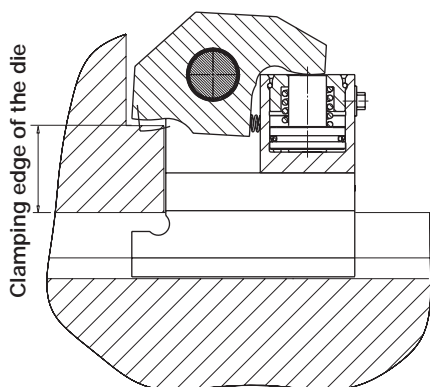

#### Functional dimension 'f':

clamping stroke  
+ height of die clamping edge  
+ web height of T-slot  
= dimension 'f'

Recommended accessories:  
**Angular rotary coupling (M 8S / G 1/4)**  
For easier handling when changing dies.  
Max. operating pressure: 400 bar.  
**Part no. 9208-043**

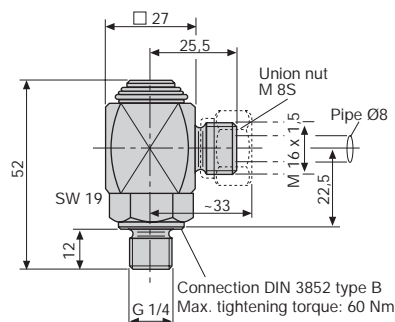

# 3.2201

03/2006

**Hilma-Römheld GmbH**

Schützenstraße 74 · D-57271 Hilchenbach

Phone +49 (0) 2733 / 281-0 · Fax +49 (0) 2733 / 281-113 · www.hilma.de

Subject to technical modification

2

# Clamping block - Angular clamp single-acting with spring return



# HILMA

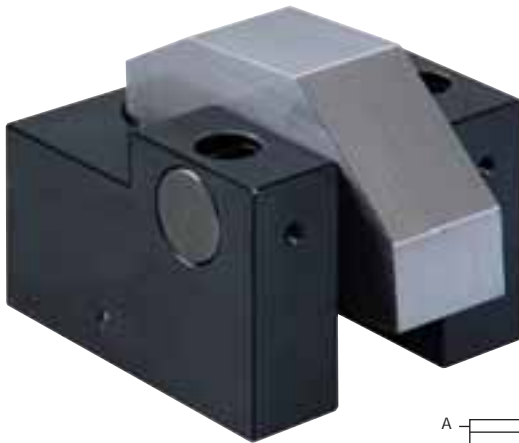

### Applications:

- ▶ on press beds and rams
- ▶ on machines and equipment for clamping and locking
- ▶ when the available space is limited

### Function:

The workpiece is clamped on its clamping edge by applying hydraulic pressure to the piston and mechanically unclamped by spring return.

The clamping block may be fastened by screwing it directly to the press bed or flexibly so that it may be moved in combination with a T-slot adapter in the T-slots of a press bed or ram.

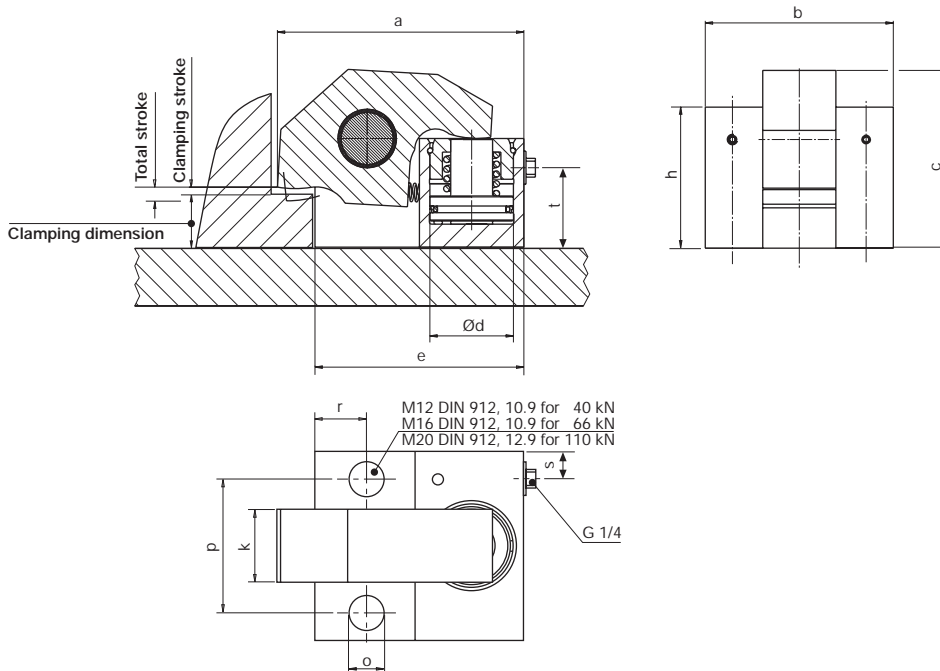
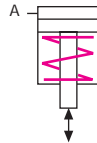

## Hydraulic clamping block without T-slot adapter

Part no.	Clamping force at 400 bar (kN)	Clamping force at 100 bar (kN)	Total stroke (mm)	Clamping stroke (mm)	Clamping dimension (mm)	Oil consumption (cm <sup>3</sup> )	Dimensions in mm												Weight (kg)
							a	b	c	d	e	h	k	o	p	r	s	t	
8.2312.0101	40	10	5,5	2,5	20,5	6,5	101	75	77	32	85	62,5	25	12,5	50	20	13	32	2,6
8.2314.0501	66	16,5	6	3	25	10	118	90	85	40	100	67,5	35	16,5	64	25	13	38	4,0
8.2315.0501	110	27,5	6	3	32	16	147	120	105	50	125	85,0	55	22,0	90	30	20	45	8,6

Max. operating pressure: 400 bar.

Other sizes are available on request. Please consult us if aggressive fluids are used

Fastening screws are not included.

With position control for version 66 kN, **Part No.: 8.2314.0504**