

# Wedge clamp, double-acting, for dies with tapered clamping edge, with locking bolt

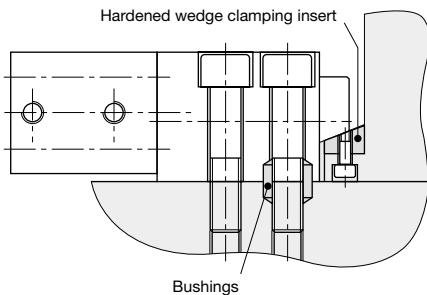

# HILMA

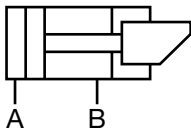
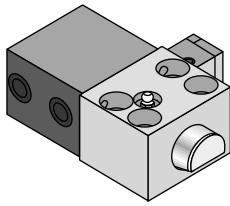

**Retrofit:** In many cases, existing dies can be standardised by adding **wedge inserts**. Max. hardness: 50 HRC.

The occurring transverse forces must be absorbed by **bushings** to be drilled into the fixture plate (see table for accessories)

**Please note:**

In case of incorrect operation of the wedge clamping element, the clamping bolt may fully retract into the guide housing and thus cause the upper die falling off the slide.

The greasing intervals (high-temperature grease) should be scheduled in accordance with the operating conditions. **Greasing of the clamping bolt should only be made with the elements being retracted.**

Clamping elements with wedge clamping bolt must be protected against dirt, scale, swarf, coolant, etc. by means of a suitable covering.

Dies clamped by means of wedge clamping elements are subject to transverse forces which may be strong enough to displace them. Therefore, location pins or suitable limit stops should be provided, in order to keep the dies in their correct position.

When using wedge clamping elements on the press slide, it is recommended that multiple-circuit hydraulic supply of the clamping elements and pilot-controlled check valves are used in the clamping lines for securing hydraulic clamping.

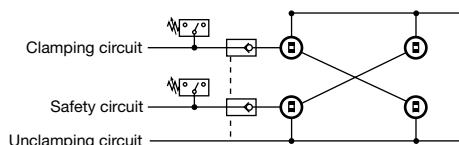

**Application:**

- ▶ safe clamping of dies with a tapered clamping edge
- ▶ for clamping of dies on a press bed and slide
- ▶ for clamping of dies in injection moulding machines

**Design:**

Double-acting wedge clamp for clamping dies on a press bed or slide or for clamping dies in injection moulding machines.

The wedge clamp consists of a hydraulic block cylinder and a piston guided in a housing.

The clamping bolt is provided with 20° bevel to clamp on the bevelled clamping surface of the die.

Based on the internal design of the wedge clamp and the 20° clamping bevel the system is providing internal friction. For reasons of safety and in order to comply with the specifications of the 'Machinery' directive no. ML98/37/EG, hydraulic pressure must always be maintained.

When upper dies are clamped by wedge clamps, they must be secured mechanically when maintenance work is carried out.

**Special features:**

- ▶ available in sizes between 25 kN and 630 kN
- ▶ high functional reliability ensured by position monitoring and an automatic cycle
- ▶ rugged and well-proven clamping element with high degree of safety and long service life

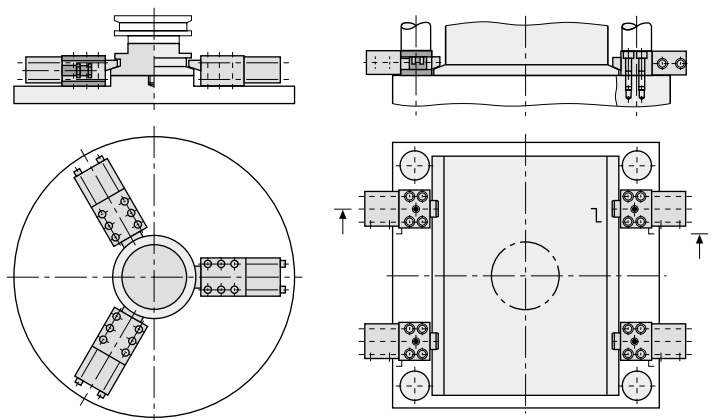

**Principle of die clamping**

In general, dies with round geometry are clamped using three clamping elements for each half, whereas dies with square or rectangular geometry are clamped using four clamping elements for each half



## Wedge clamps with locking bolt

### Wedge clamps for maximum safety:

The locking bolt of the wedge clamp is prevented from retracting using an additional locking cylinder. Only after the locking bolt has been unlocked can the clamping position be used.

Resistant to temperatures of up to 160°C (higher temperatures on request)

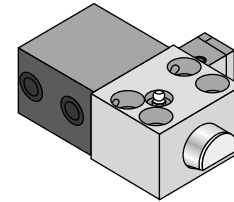
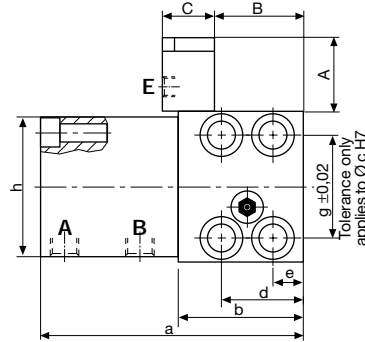
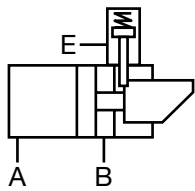
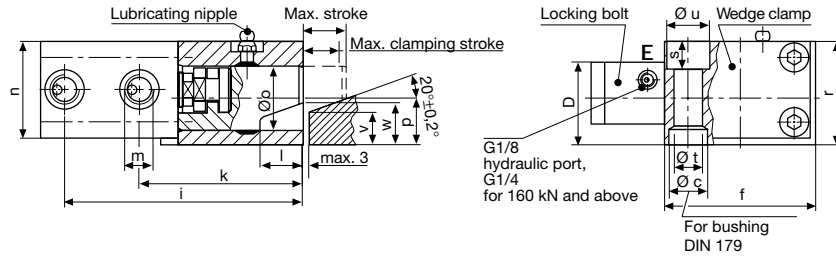

\* In the case of the 25 kN version, the lubricating nipples protrude by 5 mm and are offset by 9.5 mm

Max. clamping force*	(kN)	25	50	100	160	250	400	630
Perm. operating pressure**	(kN)	35	65	130	210	320	520	820
Screw property class 8.8								
Max. operating pressure	(bar)	350	275	350	350	350	350	350
Cylinder Ø	(mm)	25	40	50	63	80	100	125
Max. stroke	(mm)	20	25	25	30	32	40	40
Clamping stroke	(mm)	15 - 18	18 - 22	19 - 22	23 - 27	24 - 29	30 - 36	30 - 36
Oil consumpt. clamping/unlocking	(cm <sup>3</sup> )	10/3	31/3	49/3	94/2,5	161/2,5	314/2,5	491/2,5
a	(mm)	122	157	190	227	267	310	375
b	(mm)	58	78	100	125	150	180	225
Ø c H7 x depth	(mm)	18/7	26/9	30/11	35/11	48/13	55/16	62/16
d	(mm)	38	46	58	75	78	95	108
e	(mm)	14	16	20	25	26	32	38
f	(mm)	70	95	120	150	200	240	280
g	(mm)	48	65	85	106	140	180	210
h	(mm)	65	85	100	125	160	200	230
i	(mm)	111	146	177	210	246	285	344
k	(mm)	76	102	127	151	184	215	272
l	(mm)	20	25	26	32	40	45	50
m	(mm)	G 1/4	G 1/4	G 1/4	G 1/2	G 1/2	G 1/2	G 1/2
n	(mm)	45	63	75	95	120	150	180
Ø o	(mm)	30	40	55	70	80	100	125
p	(mm)	21,5	28	37	49	55	75	85
r	(mm)	48	65	80	105	125	160	190
s	(mm)	13	18	20	26	32	38	44
Ø t	(mm)	13	17	21	26	33	39	45
Ø u	(mm)	20	26	32	40	48	57	66
v	(mm)	15	18	25	30	30	50	60
w	(mm)	17,5	21,2	28,2	34,7	35,8	57,8	67,8
A	(mm)	57,5	57,5	57,5	60	60	65	65
B	(mm)	27	44	66	94	119	144,5	189,5
C	(mm)	40	40	40	45	45	40	40
D	(mm)	48	58	67	89	95	110	120
Screw DIN 912-8.8 (4 pcs.)		M 12	M 16	M 20	M 24	M 30	M 36	M 42
Tightening torque	(Nm)	86	210	410	710	1450	2520	4050
Weight	(kg)	3,0	6,5	11,4	21,7	41	74,7	126
Part no.		8.2403.1500	8.2404.1500	8.2405.1500	8.2406.1500	8.2407.1500	8.2408.1500	8.2409.1500
<b>Accessories</b>								
Bushings DIN 179		12 x 12	17 x 16	21 x 20	26 x 20	32 x 25	38 x 30	44 x 30
Part no.		3300 285	3300 287	3300 288	3300 289	3300 420	3300 430	3300 440

\*Clamping force \*\*permissible retention force (for details, see page 4)



## Wedge clamp with locking bolt + position monitoring

### Wedge clamps for maximum safety:

The locking bolt of the wedge clamp is prevented from retracting using an additional locking cylinder. Only after the locking bolt has been unlocked can the clamping position be used.

Resistant to temperatures of up to 100°C\*\*\*

Cable length: 250 mm

5-pole plug

Pin assignment:

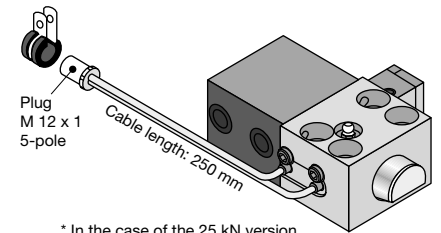
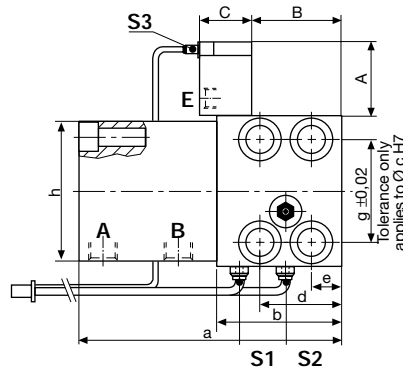
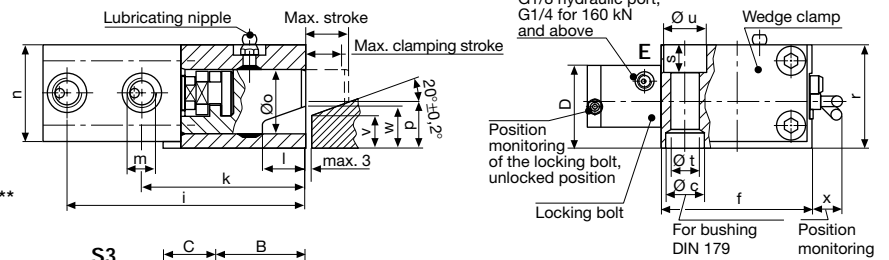
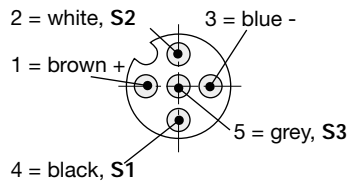

\* In the case of the 25 kN version, the lubricating nipples protrude by 5 mm and are offset by 9.5 mm

Max. clamping force*	(kN)	25	50	100	160	250	400	630
Perm. operating pressure**	(kN)	35	65	130	210	320	520	820
Screw property class 8.8								
Max. operating pressure	(bar)	350	275	350	350	350	350	350
Cylinder Ø	(mm)	25	40	50	63	80	100	125
Max. stroke	(mm)	20	25	25	30	32	40	40
Clamping stroke	(mm)	15 - 18	18 - 22	19 - 22	23 - 27	24 - 29	30 - 36	30 - 36
Oil consumpt. clamping/unlocking	(cm³)	10/3	31/3	49/3	94/2,5	161/2,5	314/2,5	491/2,5
a	(mm)	122	157	190	227	267	310	375
b	(mm)	58	78	100	125	150	180	225
Ø c H7 x depth	(mm)	18/7	26/9	30/11	35/11	48/13	55/16	62/16
d	(mm)	38	46	58	75	78	95	108
e	(mm)	14	16	20	25	26	32	38
f	(mm)	70	95	120	150	200	240	280
g	(mm)	48	65	85	106	140	180	210
h	(mm)	65	85	100	125	160	200	230
i	(mm)	111	146	177	210	246	285	344
k	(mm)	76	102	127	151	184	215	272
l	(mm)	20	25	26	32	40	45	50
m	(mm)	G 1/4	G 1/4	G 1/4	G 1/2	G 1/2	G 1/2	G 1/2
n	(mm)	45	63	75	95	120	150	180
Ø o	(mm)	30	40	55	70	80	100	125
p	(mm)	21,5	28	37	49	55	75	85
r	(mm)	48	65	80	105	125	160	190
s	(mm)	13	18	20	26	32	38	44
Ø t	(mm)	13	17	21	26	33	39	45
Ø u	(mm)	20	26	32	40	48	57	66
v	(mm)	15	18	25	30	30	50	60
w	(mm)	17,5	21,2	28,2	34,7	35,8	57,8	67,8
x Position monitoring	(mm)	12	5	0	0	0	0	0
A	(mm)	57,5	57,5	57,5	60	60	65	65
B	(mm)	27	44	66	94	119	144,5	189,5
C	(mm)	40	40	40	45	45	40	40
D	(mm)	48	58	67	89	95	110	120
Screw DIN 912-8.8 (4 pcs.)		M 12	M 16	M 20	M 24	M 30	M 36	M 42
Tightening torque	(Nm)	86	210	410	710	1450	2520	4050
Weight	(kg)	3,0	6,5	11,4	21,7	41	74,7	126
Part no.		8.2403.3000	8.2404.3000	8.2405.3000	8.2406.3000	8.2407.3000	8.2408.3000	8.2409.3000
<b>Accessories</b>								
Bushings DIN 179		12 x 12	17 x 16	21 x 20	26 x 20	32 x 25	38 x 30	44 x 30
Part no.		3300 285	3300 287	3300 288	3300 289	3300 420	3300 430	3300 440

\*Clamping force \*\*permissible retention force (for details, see page 4), \*\*\* 120°C for 1000 working hours