

Application:

▶ In connection with tie rods, lead screws and threaded rods, for clamping and locking dies on presses and machines

Hollow piston cylinder, single-acting, without spring return, as a pulling or pressing cylinder

Can be attached, screwed or flange-mounted in any position. The clamping force is built up by applying pressure to the piston and the piston is returned by external action. The piston is provided with a through hole and is hardened and ground. The housing is made from heat-treatable steel and its surface is burnished.

Hollow piston cylinder, single-acting, with spring return, as a pulling or pressing cylinder

Can be attached, screwed or flange-mounted in any position. The clamping force is built up by applying pressure to the piston and the piston is returned by a spring. The piston is provided with a through hole and is hardened and ground. The housing is made from heat-treatable steel and its surface is burnished.

Hollow piston cylinder, single-acting, as a pulling or pressing cylinder

This cylinder is very suitable for clamping mechanical clamping bars on die bending presses and folding presses. The clamping force is built up by applying pressure to the piston and the piston is returned by a spring which is installed in the clamping bar. The piston is provided with a through hole and is hardened and ground. For an optimum adaptation to the clamping surface, the hollow piston cylinder may be provided with a washer with a spherical seal.

Special features:

- ▶ flat and compact design
- ▶ steady piston movement
- ▶ stroke limited even with max. oil pressure
- ▶ rapid and easy retrofit
- ▶ ideal power transmission

For power units,
please see product group 7
For accessories,
please see product group 11



HILMA



Hollow piston cylinder single-acting, without spring return

Clamping force at 100 bar (kN)	8,7	13,5	21	34,3
at 400 bar (kN)	34,8	54	84	137,2
Stroke h (mm)	12	12	15	15
Piston restoring force (kN)	0,18	0,27	0,42	0,70
Piston area (cm ²)	8,7	13,5	21	34,3
Oil consum./1 mm stroke (cm ³)	0,9	1,4	2,1	3,5
a (mm)	61	61	72	72
b (mm)	11	15	18,5	24
c (mm)	22	22	27,5	27,5
d (mm)	44	55	68	84
e (mm)	60	75	93	113
f (mm)	28	38	54	60
g (mm)	40	50	63	80
i (mm)	16,5	20,5	24,5	30,5
k (mm)	22	28	36	45
l (mm)	M52 x 1,5	M72 x 1,5	M90 x 2	M110 x 2
Weight (kg)	1	1,7	3,1	4,6
Part no.	1303 003	1305 003	1307 003	1309 003

Max. operating pressure: 400 bar.
Special designs are available on request.

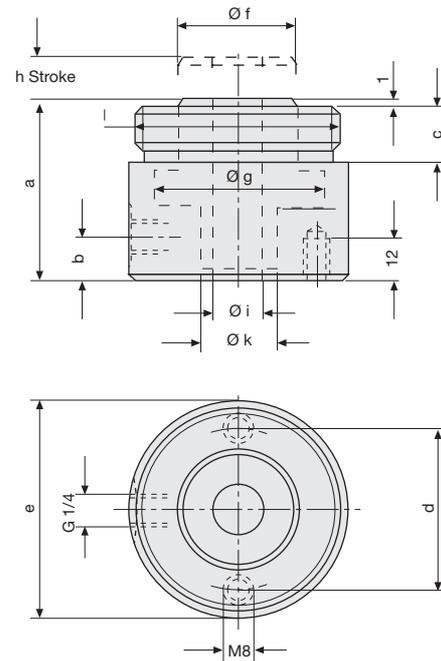

Examples for application

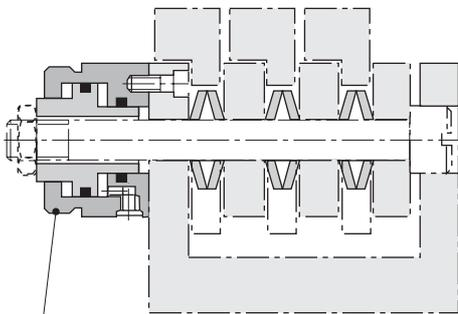

Hollow piston cylinder

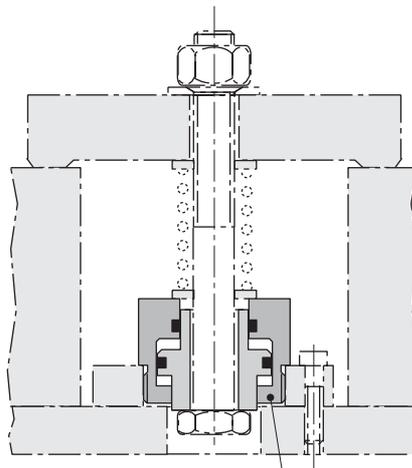

Hollow piston cylinders

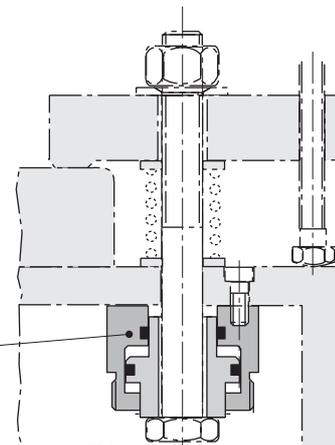

2.1300

03/2006

Hilma-Römheld GmbH

Schützenstraße 74 · D-57271 Hilchenbach

Phone +49 (0) 2733 / 281-0 · Fax +49 (0) 2733 / 281-113 · www.hilma.de

Subject to technical modification

Hollow piston cylinder single-acting, with spring return



HILMA

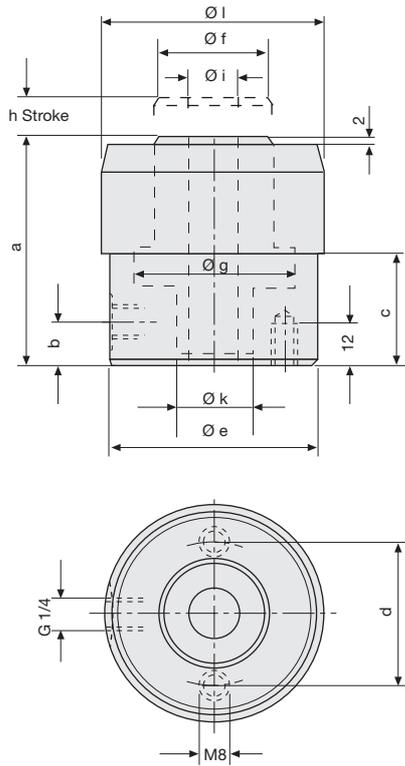

Clamping force at 100 bar (kN)	8,7	13,5	21	34,3
Clamping force at 400 bar (kN)	34,8	54	84	137,2
Stroke h (mm)	12	12	15	15
Spring power (kN)	0,26	0,36	0,50	0,75
Piston area (cm ²)	8,7	13,5	21	34,3
Oil consum./1 mm stroke (cm ³)	0,9	1,4	2,1	3,5
a (mm)	76	76	97	97
b (mm)	11	15	18,5	24
c (mm)	38	38	41	41
d (mm)	44	55	68	84
e (mm)	60	75	93	113
f (mm)	28	38	45	58
g (mm)	40	50	63	80
i (mm)	16,5	20,5	24,5	30,5
k (mm)	22	28	36	45
l (mm)	60	80	100	120
Weight (kg)	1,3	2,2	4,2	6,1
Part no.	1323 003	1325 003	1327 003	1329 003

Max. operating pressure: 400 bar.

Special designs are available on request.

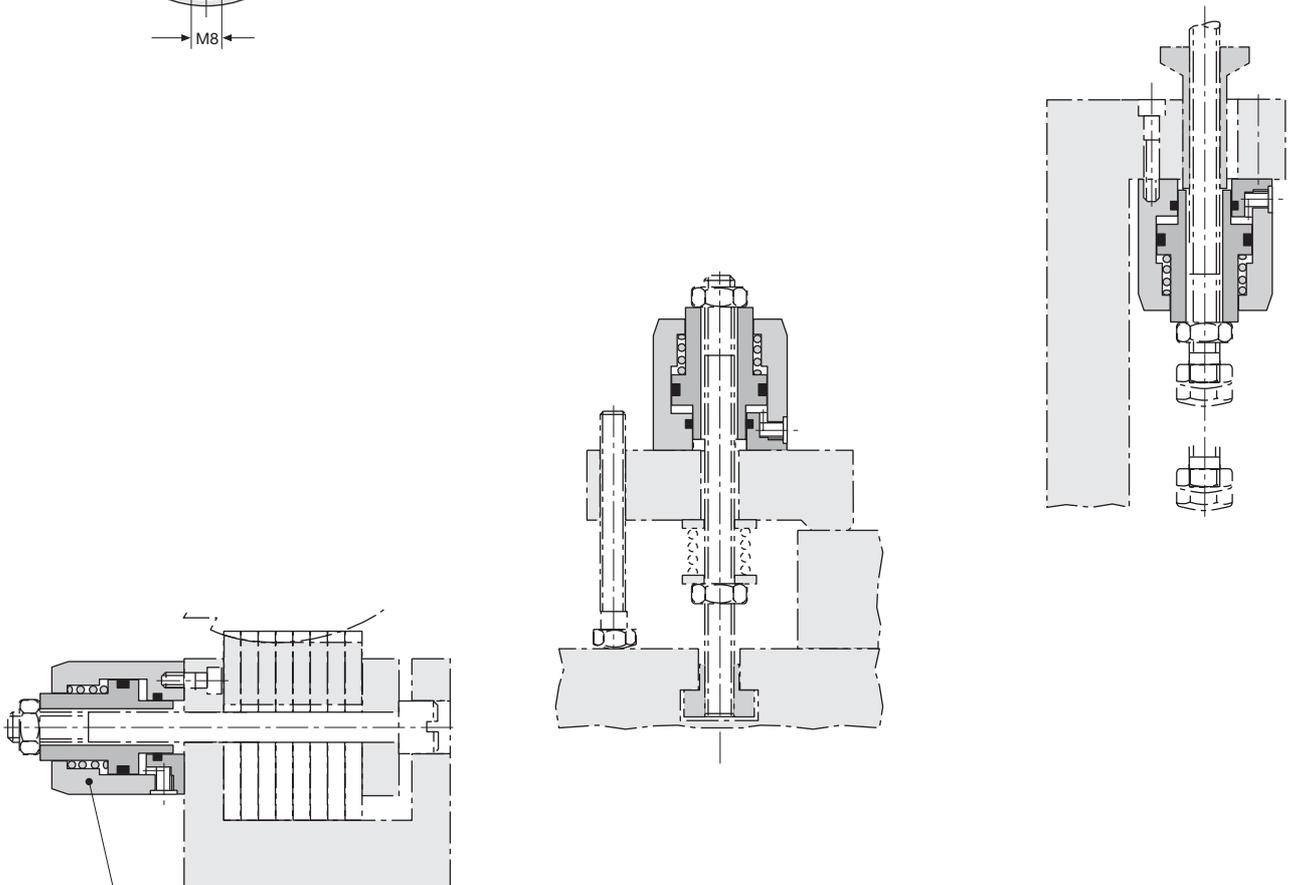

Hollow piston cylinder



HILMA



Short-stroke hollow piston cylinder, single-acting

Clamping force at 100 bar (kN)	5,5	13,5
at 400 bar (kN)	22	54
for screw	M 12	M 16
Stroke h (mm)	2,5	3,0
Pull-back spring power (kN)	0,27	0,67
Piston area (cm ²)	5,5	13,5
Oil consum./1 mm stroke (cm ³)	0,6	1,4
a (mm)	33	46
b (mm)	30,6	41
c (mm)	15	20
d (mm)	12	18
Ø e (mm)	50	80
Ø f (mm)	36	56
Washer with spherical seal	C 21	C 31
Ø i (mm)	13	18
Ø k (mm)	22	30
p	M 12 x 1,5	M 14 x 1,5
r	G 1/8	G 1/4
s (mm)	5,2	8,6
Ø t (mm)	30	48
Weight (kg)	0,4	1,4
Part no.	1830 011	1830 012
Part no. washer with spherical seal	5700 028	5700 029
Part no. pull-back spring	5700 031	5700 032

Max. operating pressure: 400 bar.

Special designs are available on request.

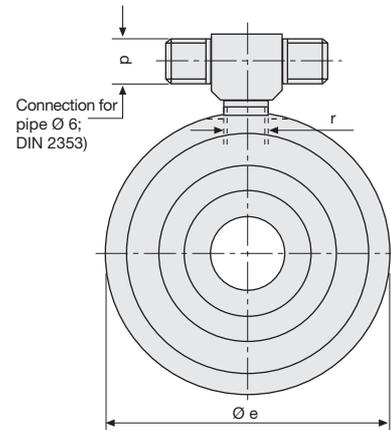
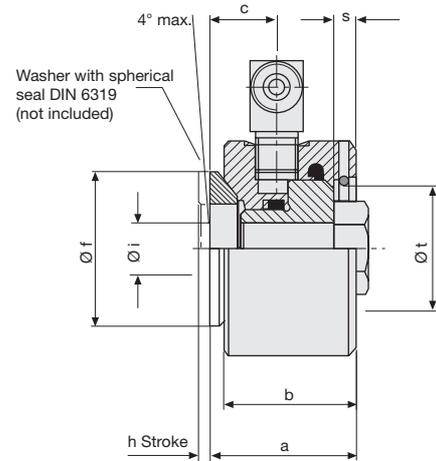

Examples for application

Clamping of a form tool using a short-stroke hollow piston cylinder and a mechanical flat clamping bar

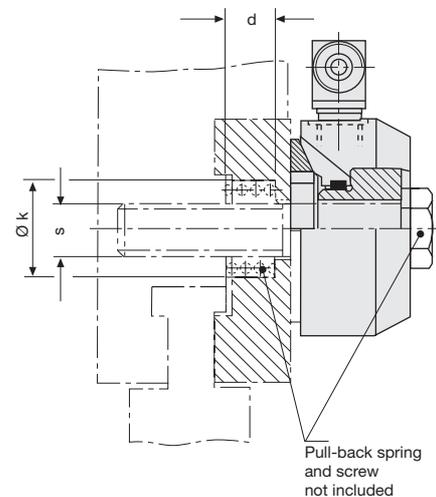
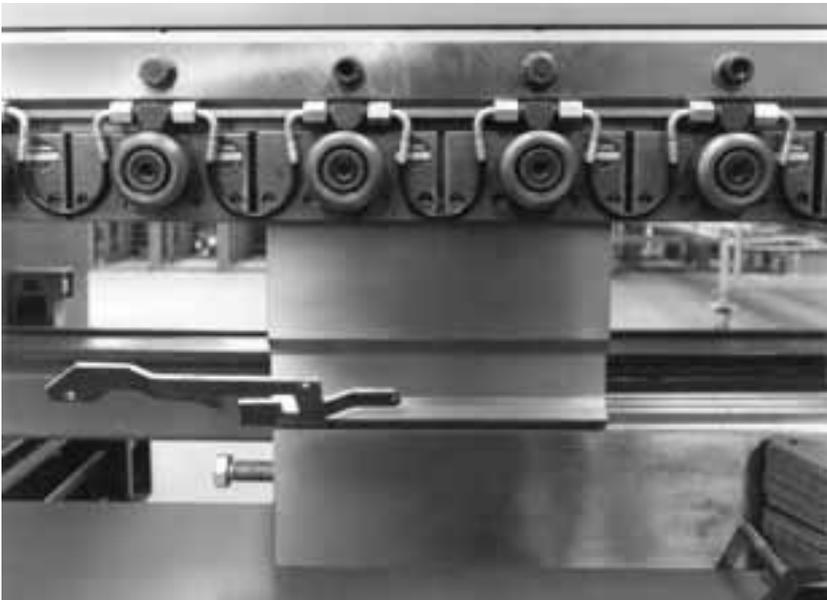

2.1330

03/2006

Hilma-Römheld GmbH

Schützenstraße 74 · D-57271 Hilchenbach

Phone +49 (0) 2733 / 281-0 · Fax +49 (0) 2733 / 281-113 · www.hilma.de

Subject to technical modification