

Wedge swing clamp double-acting, with mechanical lock

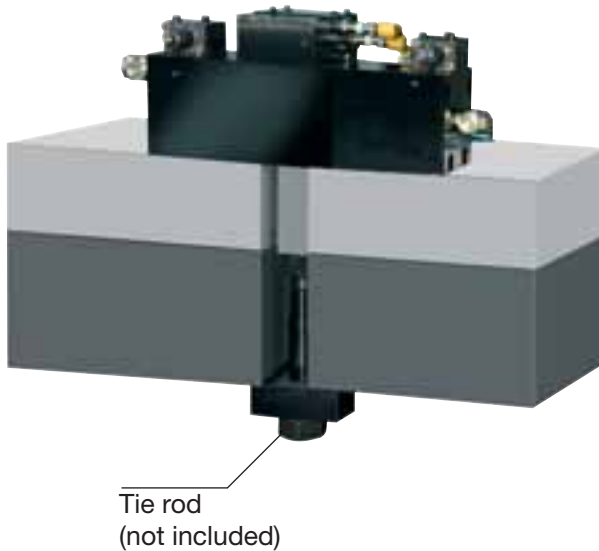

HILMA



Applications:

- ▶ on press beds and rams
- ▶ when the available space is limited

Function:

A wedge converts the stroke of the double-acting piston into a stroke of the tie rod. In order to release the die, the tie rod pivots by a maximum of 15°. The swing movement of the tie rod is performed by a separate swivel cylinder which is actuated by sequence valves. The clamping force is transmitted to the clamping point in the axial direction of the tie rod. The clamping and unclamping positions are monitored by inductive proximity switches. The mechanically locked wedge prevents unintentional unclamping of the die even if there is a loss of pressure.

Special features:

- ▶ clamping stroke up to 9.5 mm, therefore high adaptability to different clamping edge heights
- ▶ high functional reliability ensured by
 - mechanical lock
 - position monitoring
 - automatic cycle
- ▶ only 2 hydraulic ports
- ▶ very suitable for retrofit to press bed and slide

Position monitoring

The wedge swing clamp is supplied with proximity switches for monitoring the clamping and unclamping position. The switch for the clamping position only reacts if the tie rod is in a vertical position and within the clamping range. If the clamping element performs the full clamping stroke, the proximity switch is released, and the signal disappears. The proximity switches are installed on the side of the swivel cylinder (see drawing). In case of part no. 4607-000, the proximity switches are installed on the front side of the housing.

Proximity switches PNP

Supply voltage: 12 - 24V DC
Nom. tripping cycle 2 mm
Load: 200mA
Proximity switch and LED display
Plug with 5 m connecting cable 3 x 0.34

Retrofit

Retrofitting to existing presses can be achieved using an intermediate flange

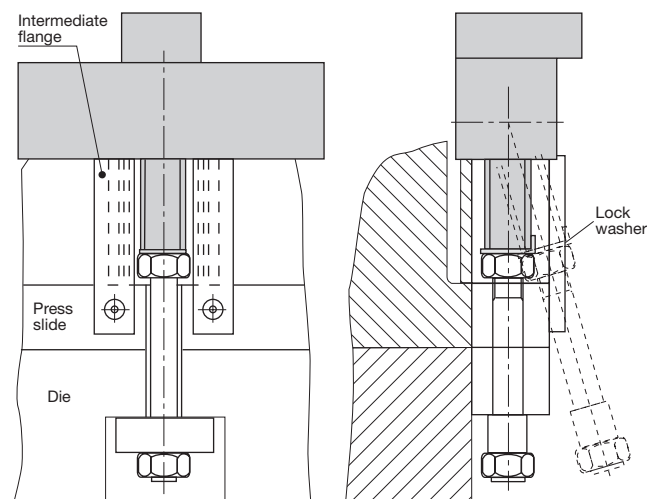



HILMA

Wedge swing clamp double-acting, with mechanical lock

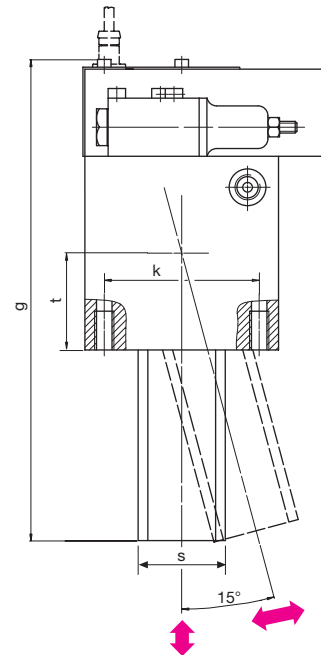
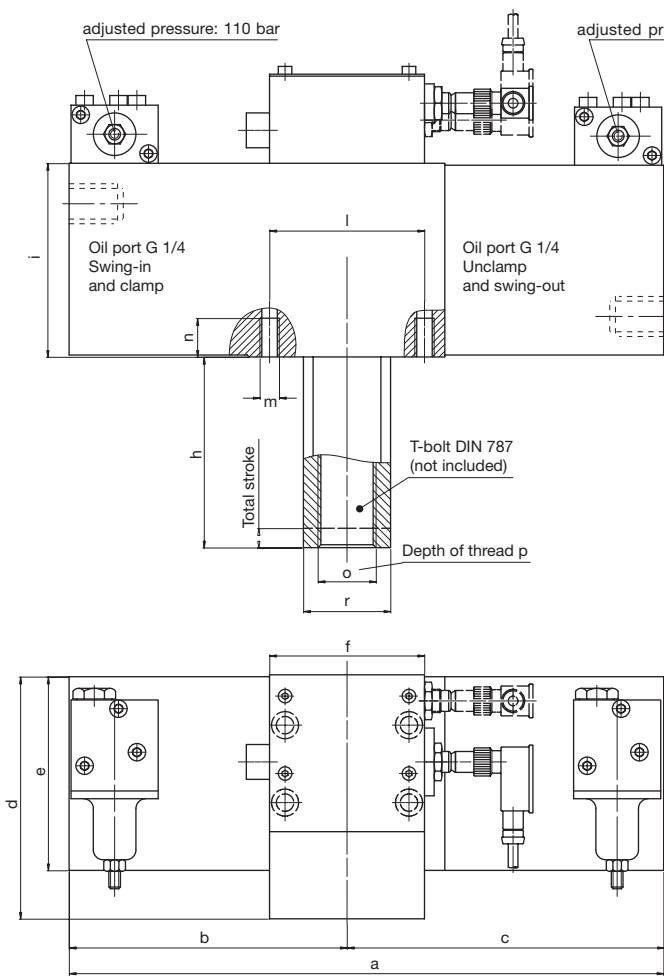

Control port for tie rod operation

As an option, the wedge swing clamp is available with an additional pipe connection for separate control of the swing-in movement of the swivel cylinder. In this case, the integral sequence valve (see drawing, left side) is replaced by an hydraulic oil port. Thus, each element must be connected by three pipes. Combined with a suitable control, this system enables clamping only after all tie rods of the clamping elements have performed the swing-in movement.

If 4 or more clamping elements are used, two clamping circuits can be arranged diagonally as an additional safety measure

Hydraulic diagram

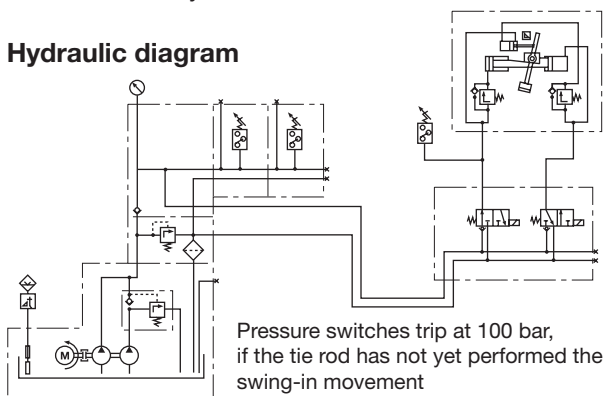

Max. clamping force (kN)	50	100
Total stroke (mm)	8	10
Useable clamping stroke (mm)	7,5	9,5
Perm. volume flow (cm ³ /s)	70	70
Min. operating pressure (bar)	150	150
Max. operating pressure (bar)	240	280
Oil consumption clamping (cm ³)	80	101
Oil consumption unclamp. (cm ³)	82,5	152
a (mm)	254	307
b (mm)	120	143,5
c (mm)	134	163,5
d (mm)	120,5	125
e (mm)	80	100
f (mm)	70	80
g (mm)	186	248,5
h (mm)	63	98,5
i (mm)	80	100
k (mm)	60	80
l (mm)	60	80
m (mm)	M 10	M 10
n (mm)	15	20
o (mm)	M 20	M 30
p (mm)	28	45
r (mm)	36	45
s (mm)	40	45
t (mm)	40	50
Part no.	4607-000	4607-001

Safety information

The tie rod is secured with a lock nut. In order to prevent it from loosening, a lock washer should be added.

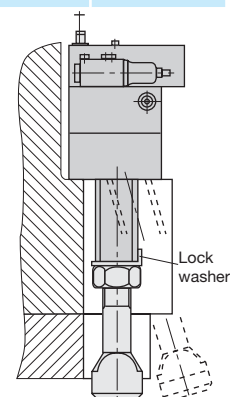

2.2240

03/2006

Hilma-Römheld GmbH

Schützenstraße 74 · D-57271 Hilchenbach

Phone +49 (0) 2733 / 281-0 · Fax +49 (0) 2733 / 281-113 · www.hilma.de

Subject to technical modification