

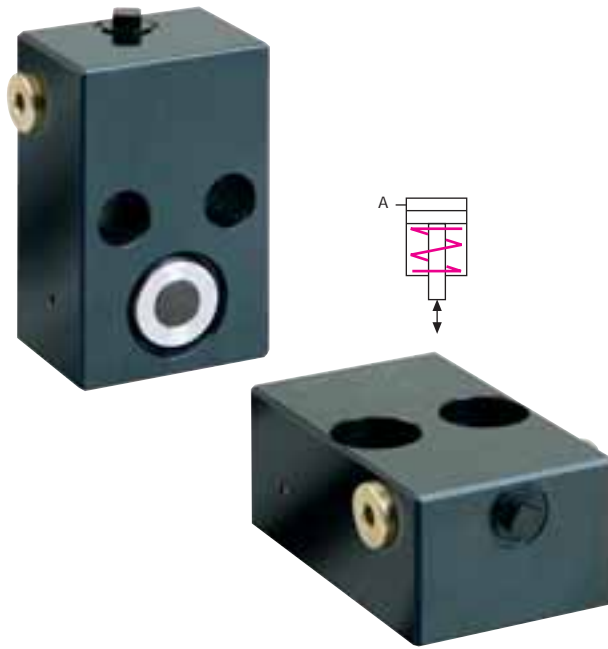

Clamping block - Sliding clamp single-acting with spring return



Applications:

- ▶ on press beds and rams
- ▶ on machines and equipment for clamping and locking
- ▶ when the available space is limited

Function:

The workpiece is clamped on its clamping edge by applying hydraulic pressure to the piston and mechanically unclamped by a spring return. The clamping block may be fastened by screwing it to stationary spacer ledges or in combination with a T-slot adapter for clamping workpieces in the T-slots of a press bed or ram.

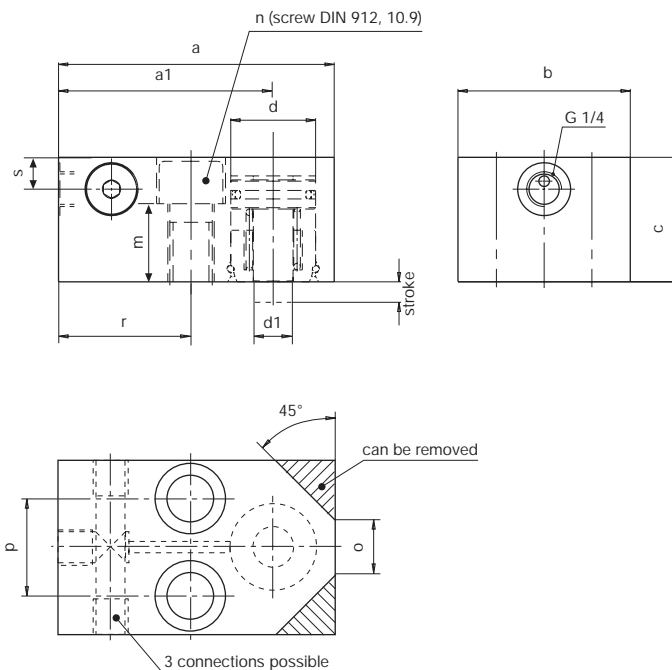

Hydraulic clamping block without T-slot adapter

Part no.	Clamping force at 400 bar (kN)	Stroke (mm)	Oil consumption (cm ³)	Dimensions in mm										Weight (kg)		
				a	a1	b	c	d	d1	m	n	o	p		r	s
8.2202.1301	19,2	8	4	95	77	65	40	25	15	24	M16	18	36	50	12,0	1,6
8.2203.1301	32	8	7	104	81	65	47	32	15	29	M16	20	36	50	15,0	2,0
8.2204.1301	50	8	10	111	85	65	50	40	20	32	M16	20	36	50	16,5	2,3
8.2205.1301	78	12	24	132	99	80	75	50	25	53	M20	28	43	57	22,0	4,9

Max. operating pressure: 400 bar.

Fastening screws M16 or M20, DIN 912, 10.9 are not included.

Clamping block - Angular clamp single-acting with spring return



HILMA

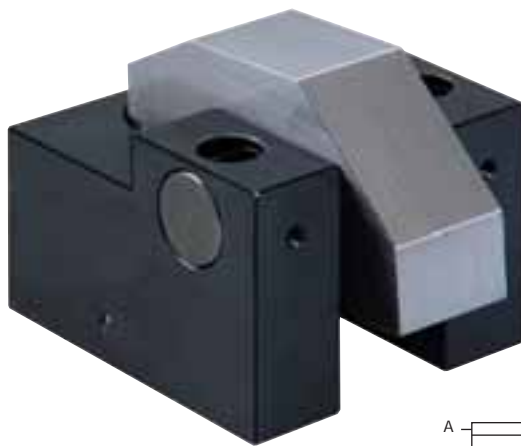

Applications:

- ▶ on press beds and rams
- ▶ on machines and equipment for clamping and locking
- ▶ when the available space is limited

Function:

The workpiece is clamped on its clamping edge by applying hydraulic pressure to the piston and mechanically unclamped by spring return.

The clamping block may be fastened by screwing it directly to the press bed or flexibly so that it may be moved in combination with a T-slot adapter in the T-slots of a press bed or ram.

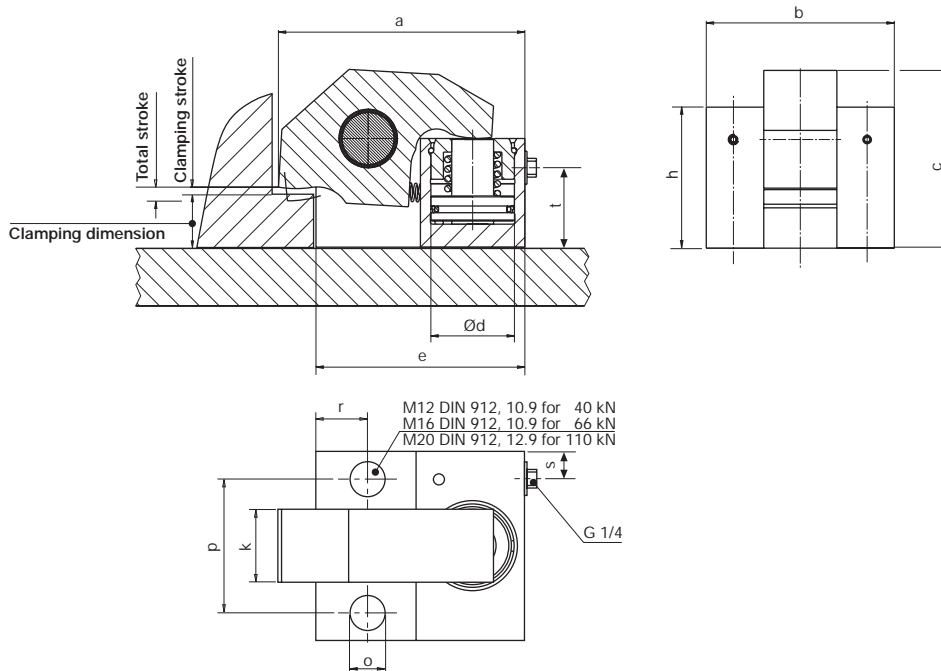
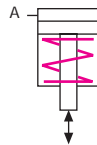

Hydraulic clamping block without T-slot adapter

Part no.	Clamping force at 400 bar (kN)	Clamping force at 100 bar (kN)	Total stroke (mm)	Clamping stroke (mm)	Clamping dimension (mm)	Oil consumption (cm ³)	Dimensions in mm											Weight (kg)	
							a	b	c	d	e	h	k	o	p	r	s		t
8.2312.0101	40	10	5,5	2,5	20,5	6,5	101	75	77	32	85	62,5	25	12,5	50	20	13	32	2,6
8.2314.0501	66	16,5	6	3	25	10	118	90	85	40	100	67,5	35	16,5	64	25	13	38	4,0
8.2315.0501	110	27,5	6	3	32	16	147	120	105	50	125	85,0	55	22,0	90	30	20	45	8,6

Max. operating pressure: 400 bar.

Other sizes are available on request. Please consult us if aggressive fluids are used

Fastening screws are not included.

With position control for version 66 kN, **Part No.:** 8.2314.0504