

Press-In Devices 40-63 kN Bench devices with electro-hydraulic control



Application

Press-in devices for assembly are preferably used in assembly processes for production of longitudinal pressed joints. In addition, the mounting conditions require frequently a C-shaped press-in device for optimised accessibility and high precision at the same time.

Advantages

- High flexibility in the operative range
- Improved ergonomics
- Quality assurance of operation
- Reduction of assembly time
- Short amortisation time
- Closed force-loop
- Defined joining forces
- Light component load
- Quick-change tooling system

Industry/applications (selection)

- ◆ Drive technology, gears box assembly
- ◆ Couplings, cardan shafts
- ◆ Compressors, pumps, hydraulic elements
- ◆ Industrial fittings
- ◆ Materials-handling technology
- ◆ Automotive industry and their suppliers
- ◆ Machine tool building
- ◆ Building and agricultural machines
- ◆ Electronics

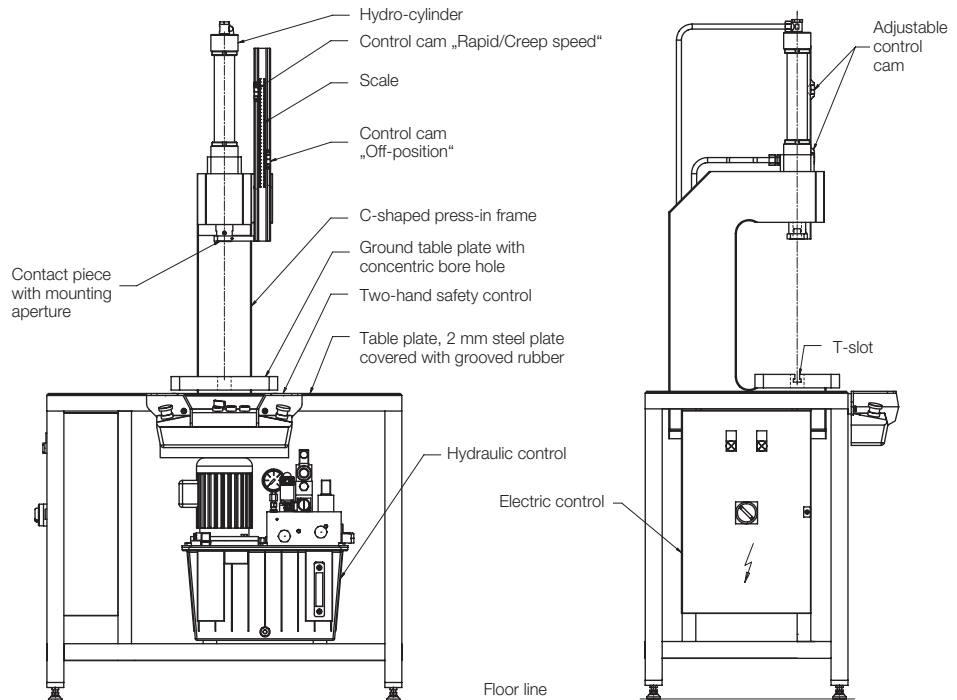

Description

Press-in device as bench device is complete functional unit and consists of 3 basic components: mechanical press-in device, electro-hydraulic control and underframe for tables. Above the table plate there are - according to the application of ergonomic design rules - the mechanical press-in device and at the table frame the two-hand safety control. The electric control box and the hydraulic power unit are installed in the lower table area. Due to safety reasons, operation of the hydraulic cylinder is always made by a two-hand safety control. The press-in device is equipped with a rapid and creep speed control and a return stroke limitation.

Application and installation instructions

When installing the press-in device it has to be considered that it will be installed on a plain surface and will be carried by all 4 legs. According to the operating instructions the electric connection has to be effected and the hydraulic power unit must be filled with mineral oil.

Application example

C-shaped press-in device 50 kN, variant version in robust welding construction with mounted electric and hydraulic control. Two-hand operating panels at the side of the press-in frame.



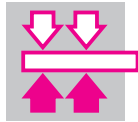

ROEMHELD

Press-in fixture 40-63 kN
with mounting aperture as per DIN 810

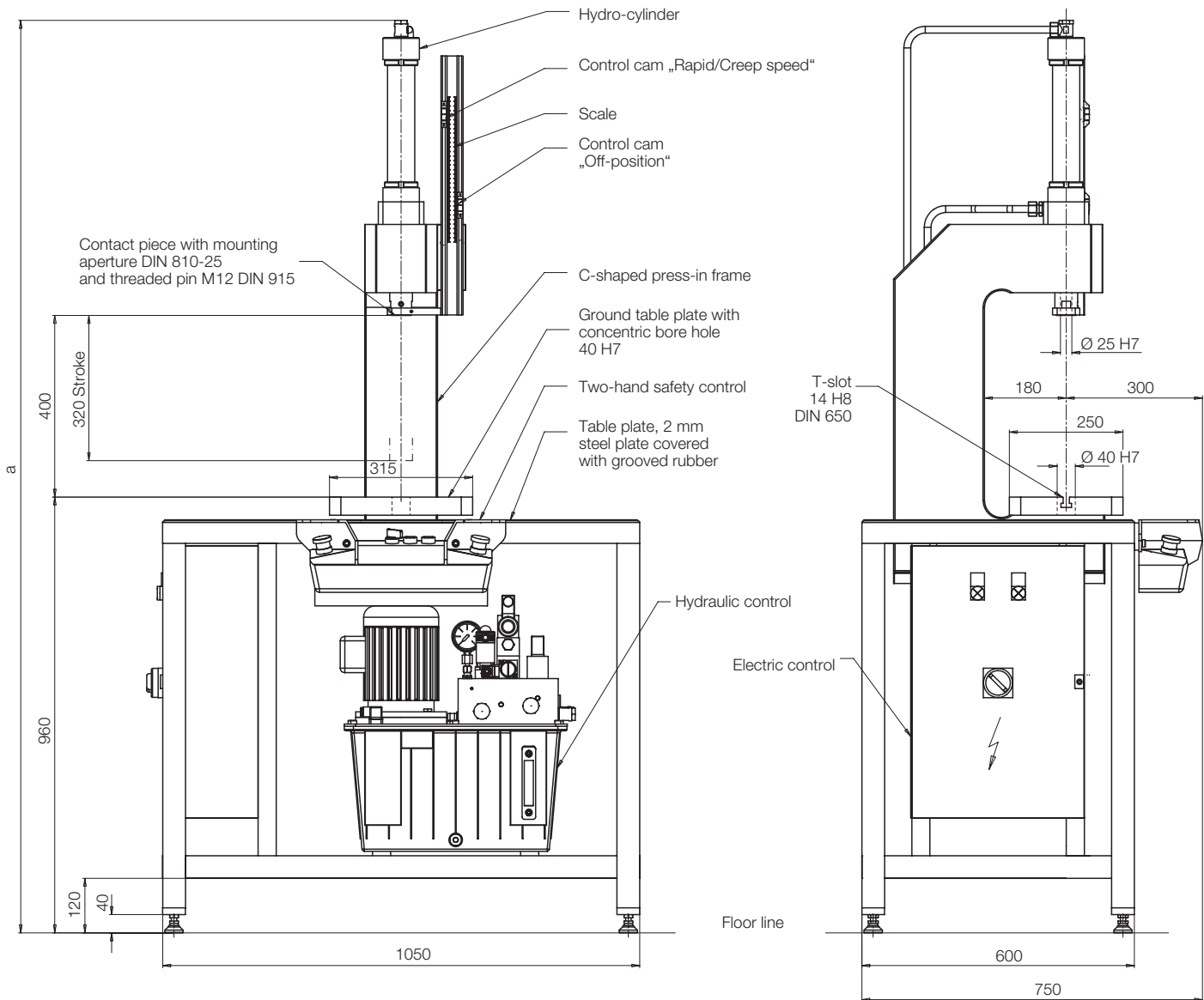

Nominal pressure force	[kN]	40	63
a	[mm]	2010	2125
Cylinder stroke	[mm]	320	320
Flow rate	[l/min]	2.0 / 6.8	3.3 / 11.9
Max. operating pressure	[bar]	200 / 40	200 / 40
Oil volume	[l]	27	40
Rating	[kW]	1.1	1.5
Electric connection		3/PE (50 Hz 400 V)	
Code class		IP 54	IP 54
v- press-in stroke	[mm/s]	18	18
v- rapids extend	[mm/s]	75	80
v- rapids retract	[mm/s]	126	135
Weight	[kg]	450	500

Part-no. **6600-270** **6600-370**

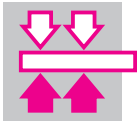

ROEMHELD

Press-in device 40-63 kN
with quick-change tooling system

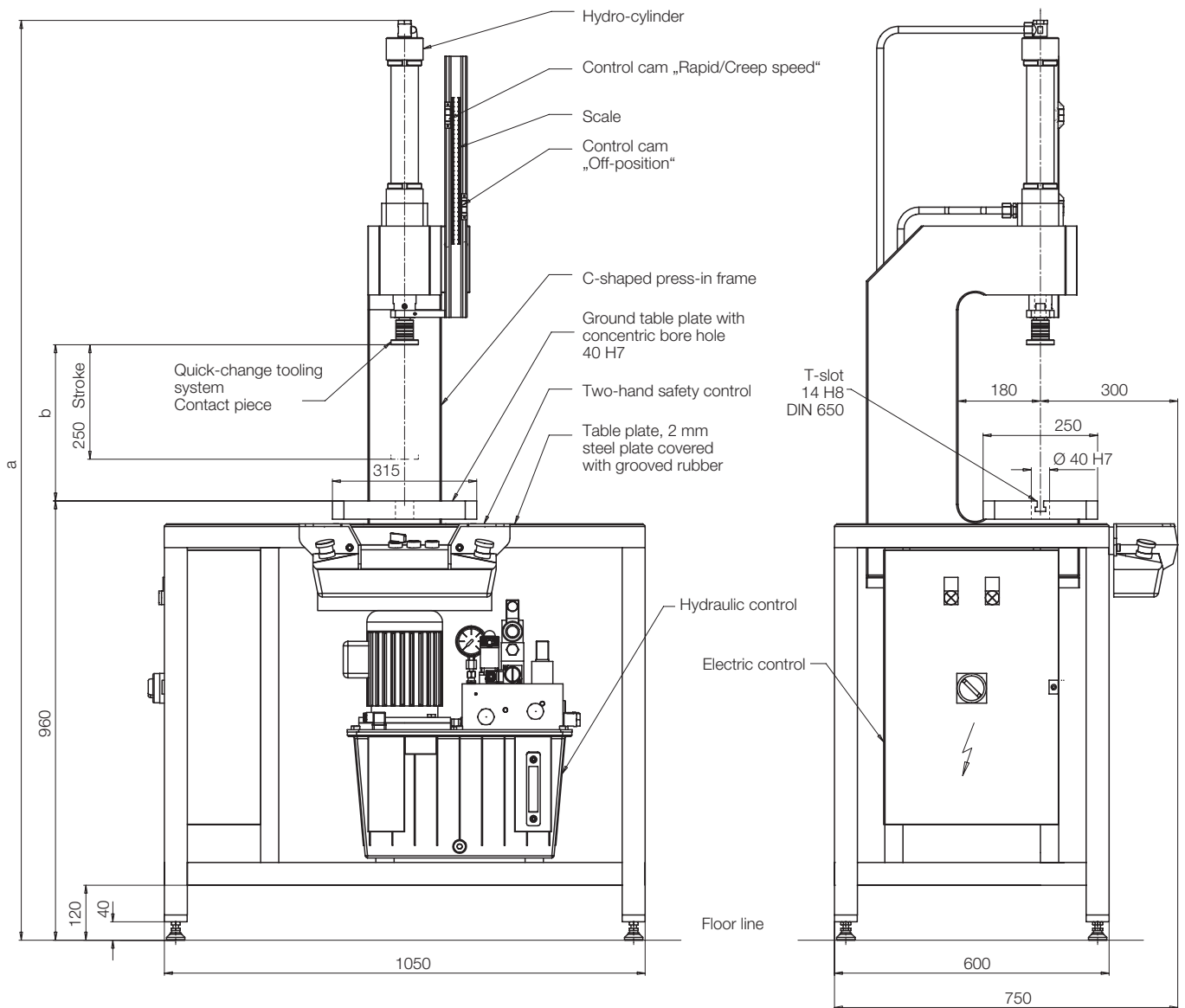

Nominal pressure force	[kN]	40	63
a	[mm]	1940	2055
b	[mm]	340	300
Cylinder stroke	[mm]	250	250
Flow rate	[l/min]	2.0 / 6.8	3.3 / 11.9
Max. operating pressure	[bar]	200 / 40	200 / 40
Oil volume	[l]	27	40
Rating	[kW]	1.1	1.5
Electric connection		3/PE (50 Hz 400 V)	
Code class		IP 54	IP 54
v- press-in stroke	[mm/s]	18	18
v- rapids extend	[mm/s]	75	80
v- rapids retract	[mm/s]	126	135
Weight	[kg]	480	530
Part-no.		6600-280	6600-380



Automatic mode

By operating the mushroom push-buttons at the two-hand operating panel simultaneously, the hydraulic cylinder extends rapidly starting from the retracted off-position. When the 1st proximity switch „rapids/creep speed“ is actuated, the control switches automatically during the motion to creep speed. When the maximum press-in pressure is obtained, reversing to retraction is automatically effected and the hydraulic cylinder retracts rapidly until the second proximity switch „Off-position“ is actuated. The switching points of the proximity switches are continuously adjustable. The lamps at the two-hand safety control indicate if the off-position and the maximum press-in pressure are achieved. The automatic mode can only be started, if the hydraulic cylinder is in the retracted off-position.

Setting mode

In addition, the functions „Extend“ and „Retract“ can be separately selected by means of a selector switch in the two-hand control. In the setting mode, the press-in device can only be operated in creep speed. The proximity switches are not in operation.

Function triggering is - in all operating conditions - only possible by operating simultaneously both mushroom push-buttons of the two-hand safety control.

Variants

- Table frame out of aluminium
- Press-in frame with additional protection cover
- Additional equipment with press-in control

Quick-change tooling system

The quick-change tooling system offers the possibility to change to other press-in contact pieces within a very short time. Uncoupling of the quick-change tooling system is made by lifting of the exterior sleeve only. The contact pieces can be detached and changed. After release of the exterior sleeve the quick-change tooling system engages automatically and locates the contact piece in a defined position. In unloaded mode the contact pieces are self-centering. During pressing-in the forces are compensated by the contact pieces and introduced to a spherical surface support, thereby they can align themselves parallel to the center line and compensate the elastic deformation of the components. A press-in operation without lateral forces and spare for the workpieces will be realized.



Contact piece

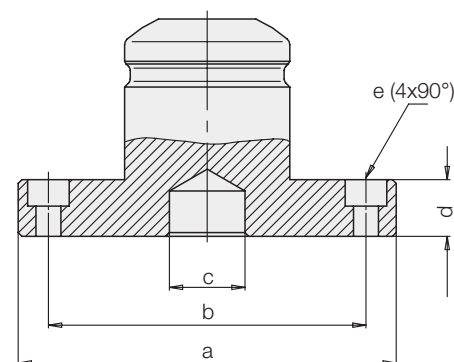

Technical characteristics –

Contact pieces

a	[mm]	60	100
b	[mm]	40	84
c	[mm]	12 H7x6	20 H7x10
d	[mm]	10	15
e	[mm]	Jm5 DIN 74	Km6 DIN 74
Weight	[kg]	0.3	1.3
for press-in device		6600-280	6600-380
Part-no.		6604-161	6604-166