

Pneumatic Swing Clamp top flange-type, for adjustable magnetic sensors double acting, max. operating pressure 7 bar

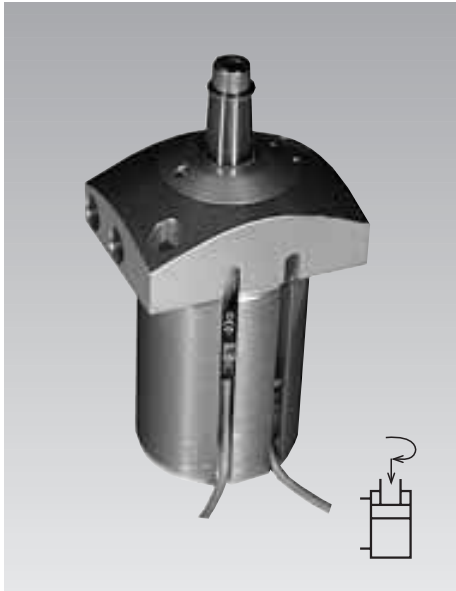

Installation examples

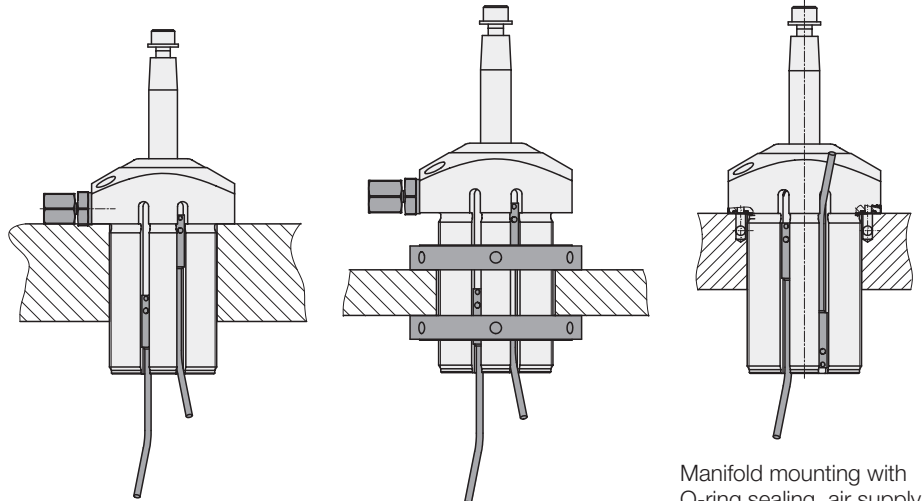

Connecting thread, mounted with socket head cap screw

Connecting thread, height adjustment by collar nuts

Manifold mounting with O-ring sealing, air supply through drilled channels in the fixture plate

Application

Pneumatic swing clamps are used for applications which require only low clamping forces. The installed magnetic piston allows monitoring of clamping and unclamping position.

Description

When pressurising the element, the clamping arm swings and lowers by 90° to the clamping position and then lowers to the clamping point. The position monitoring gives the required information regarding the position of the piston, but not regarding the position of the clamping arm. Monitoring is made by electronic sensors (see accessory) which detect the magnetic field of the magnetic piston. The switching points can be continuously adjusted by displacement of the magnetic sensors.

Special features

When adjusting the clamping screw it has to be considered that for the swing motion a part of the total stroke is required. Make sure that the swing motion can be effected without any interference. When using special clamping arms with other lengths, the corresponding operating pressures as shown in the clamping force diagram must not be exceeded.

Installation

On fixtures flange-type swing clamps or threaded versions with corresponding collar nuts can be easily adjusted to different workpiece heights.

Material

The swing clamps are supplied in corrosion resistant quality. Guide bushing, housing and piston are made of hardcoated aluminium. The piston rod is made of corrosion resistant steel.

Important notes

Operating of these pneumatic elements has to be effected with an additional service unit in order to guarantee that the clamping elements are supplied with correctly prepared compressed air.

Operating conditions, tolerances and other data see data sheet A 0.100.

Advantages

- Low built-in design possible
- Height adjustment by threaded body and collar nut
- Flange mounting by socket head cap screws
- 5 standard sizes are available
- optionally with thread connection or for manifold mounting with O-ring sealing

Versions

- Threaded body for height adjustment
- Manifold mounting with O-ring sealing

Pneumatic accessories

see data sheet J 7.400.

Connecting example

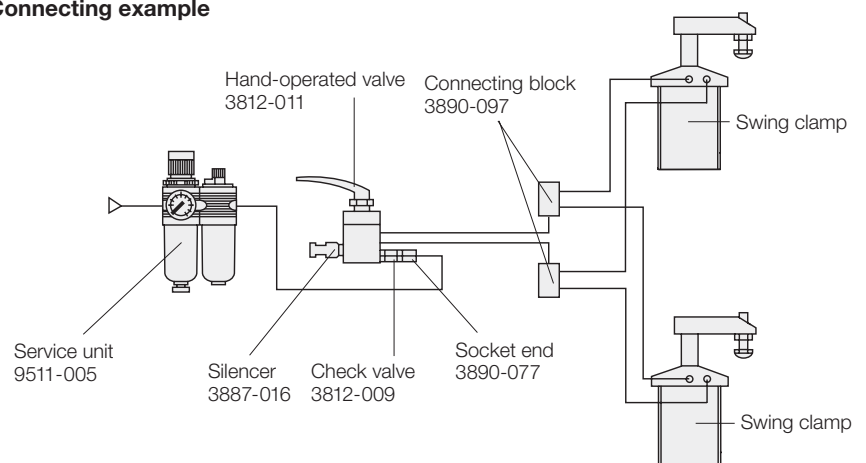

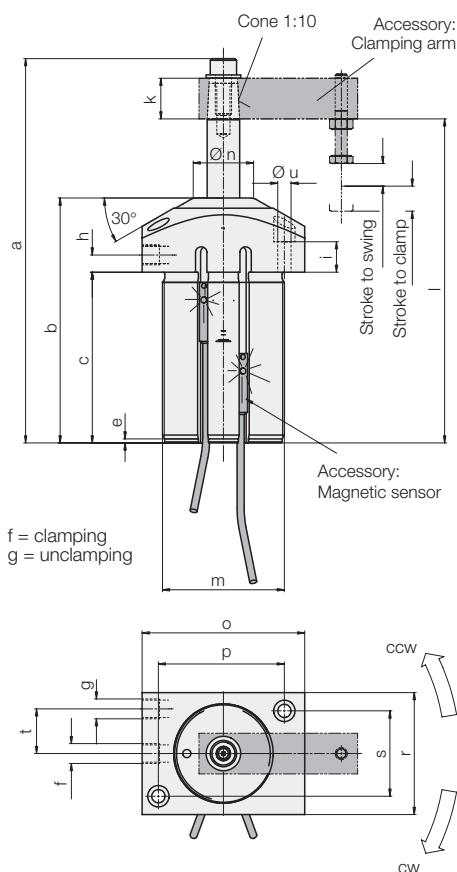

Piston Ø	[mm]	20	32	40	50	63
Piston rod Ø	[mm]	8	12	16	20	25
Stroke to swing	[mm]	7.5	9.5	17	18	23
Stroke to clamp	[mm]	7	9	15	15	18
Force to pull at 4 bar	[N]	105.5	276.4	422.2	659.7	1050.5
* air 5 bar	[N]	131.9	345.5	527.7	824.6	1313.1
pressure 6 bar	[N]	158.3	414.6	633.3	989.6	1575.8
Min. operating pressure	[bar]	3				
Max. operating pressure	[bar]	7				
Angle of rotation	[°]	90° ± 2°				
Weight	[kg]	0.3	0.6	1.0	1.5	2.6
a	[mm]	120	143	189	202	239.5
b	[mm]	76	94.5	120.5	130	150
c	[mm]	48	61	84	85	91
e	[mm]	2	2	2	2	2
f	[mm]	M5	M5	G 1/8	G 1/8	G 1/4
g	[mm]	M5	M5	G 1/8	G 1/8	G 1/4
h	[mm]	6	6.5	8.5	10	13
i	[mm]	7.5	11	15	19	27
□ k	[mm]	12	16	20	25	30
l	[mm]	103.5	119.5	159	164	197
m	[mm]	M40x1.5	M52x1.5	M60x1.5	M70x1.5	M85x2
Ø n	[mm]	14	24	30	38	42
o	[mm]	60	68	80	90	106
p	[mm]	44	54	62	72	86
r	[mm]	40	52	60	70	85
s	[mm]	25	36	42	48	66
t	[mm]	12.8	15	22	23	30.3
Ø u	[mm]	5.5	6.5	6.5	8.5	8.5
Direction of rotation cw	Part-no.	1873-103	1874-103	1875-103	1876-103	1877-103
Direction of rotation ccw	Part-no.	1873-203	1874-203	1875-203	1876-203	1877-203

* Effective clamping force see diagram (page 3)

Seat of clamping arm

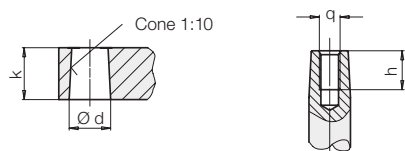

Swing clamp	Ø d +0.05	□ k	h	q
1873-X03/ -X05	7.85	12	9	M 4
1874-X03/ -X05	11.85	16	15	M 6
1875-X03/ -X05	15.85	20	19	M 8
1876-X03/ -X05	19.85	25	18	M 12
1877-X03/ -X05	24.85	30	25	M 10

Clamping arm

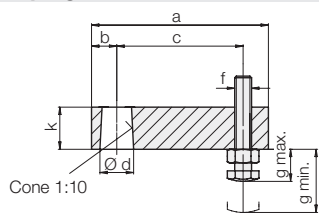

Swing clamp	a	b	c	Ø d +0.05	f	g min.	g max.	□ k	Part-no.
1873-X03/ -X05	54	7	42	7.85	M 4	8	28	12	0187-326
1874-X03/ -X05	68	10	52	11.85	M 6	12	27	16	0187-426
1875-X03/ -X05	78	12	58	15.85	M 6	12	42	20	0187-526
1876-X03/ -X05	90	14	68	19.85	M 8	15	42	25	0187-626
1877-X03/ -X05	110	18	80	24.85	M10	19	56	30	0187-726

Clamping arms for special versions

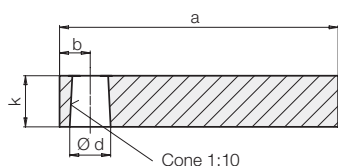

Swing clamp	a	b	Ø d +0.05	□ k	Part-no.
1873-X03/ -X05	62	7	7.85	12	3548-355
1874-X03/ -X05	72	10	11.85	16	3548-356
1875-X03/ -X05	95	12	15.85	20	3548-357
1876-X03/ -X05	116	14	19.85	25	3548-353
1877-X03/ -X05	143	18	24.85	30	3548-358

Contact bolts, dome head

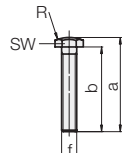

Swing clamp	a	b	f	R	SW	Part-no.
1873-X03/ -X05	32.5	30	M 4	15	7	3614-141
1874-X03/ -X05	33.5	30	M 6	20	10	3614-137
1875-X03/ -X05	48.5	45	M 6	20	10	3614-138
1876-X03/ -X05	50	45	M 8	20	13	3614-139
1877-X03/ -X05	66.5	60	M10	35	17	3614-140

Flange nut

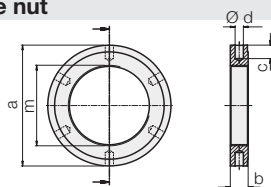

Swing clamp	Ø a	b	c	Ø d	m	Part-no.
1873-X03	62	12	8	4x6	M 40x1.5	3527-040
1874-X03	80	13	10	6x6	M 52x1.5	3527-082
1875-X03	90	13	10	6x6	M 60x1.5	3527-042
1876-X03	100	14	12	6x8	M 70x1.5	3527-083
1877-X03	120	16	12	6x8	M 85x2.0	3527-084



Effective clamping force

1873-X03

1873-X05

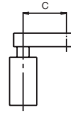
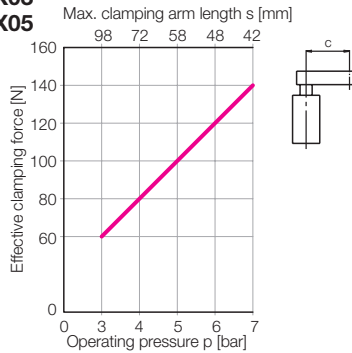

1874-X03

1874-X05

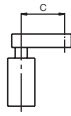
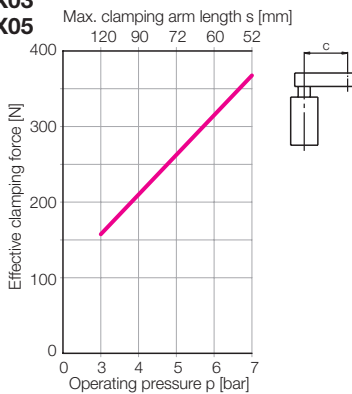

1875-X03

1875-X05

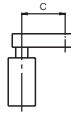
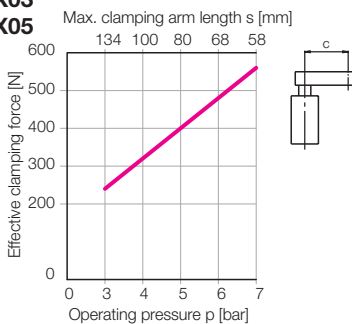

1876-X03

1876-X05

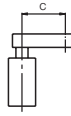
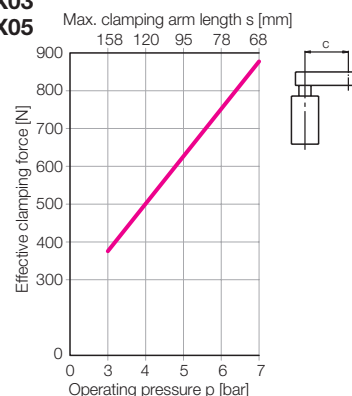

1877-X03

1877-X05

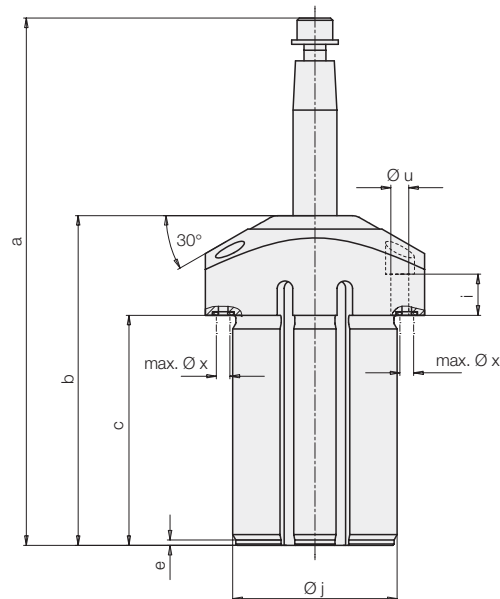
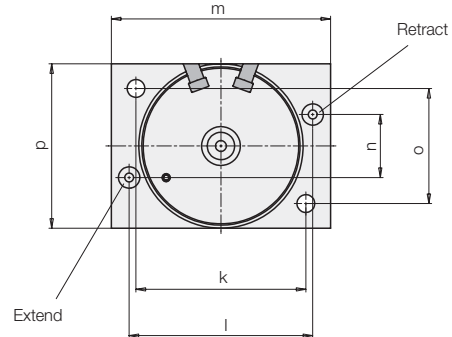
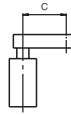
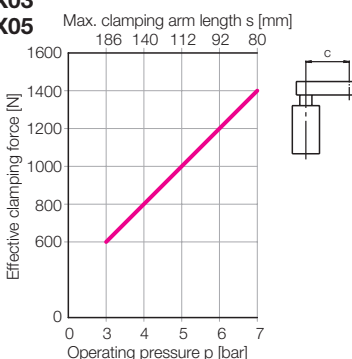

Clamping force

		1873-105	1874-105	1875-105	1876-105	1877-105
		1873-205	1874-205	1875-205	1876-205	1877-205
Piston Ø	[mm]	20	32	40	50	63
Piston rod Ø	[mm]	8	12	16	20	25
a	[mm]	120	143	189	202	239.5
b	[mm]	76	94.5	120.5	130	150
c	[mm]	48	61	84	85	91
e	[mm]	2	2	2	2	2
i	[mm]	7.5	11	15	19	27
Ø j	[mm]	40	52	60	70	85
k	[mm]	44	54	62	72	86
l	[mm]	47	56	67	76	90
m	[mm]	60	68	80	90	106
n	[mm]	18	27	23	36	40
o	[mm]	25	36	42	48	66
p	[mm]	40	52	60	70	85
Ø u	[mm]	5.5	6.5	6.5	8.5	8.5
max. Ø x	[mm]	3.5	3.5	3.5	5	5

Dimensions O-ring 4.47x1.78 4.47x1.78 4.47x1.78 7x1.5 7x1.5

Part-no. spare O-ring 3000-968 3000-968 3000-968 3000-342 3000-342

O-rings are included in delivery. Other dimensions see page 2.



Compared with traditional reed switches the electronic magnetic sensors offer the following advantages:

- Indifference to shock and vibration
- Bounce-free output signal
- Only one switching point
- Wear resistant
- Protection against reverse battery
- Protected against short circuits

Electric connection is made as per traditional inductive proximity switches; up to four magnetic sensors can be connected in series.

Important notes

Steel can influence the magnetic field of the magnetic piston and thereby the position of the switching point. If the pneumatic swing clamp is flange mounted on a steel plate, the sensor has to be adjusted by displacement in the mounted condition. If the magnetic sensor is outside of a protecting bore hole and is exposed to changing influences of adjacent steel parts, e.g. swarf, protection for 30 mm has to be provided.

Electronic magnetic sensor

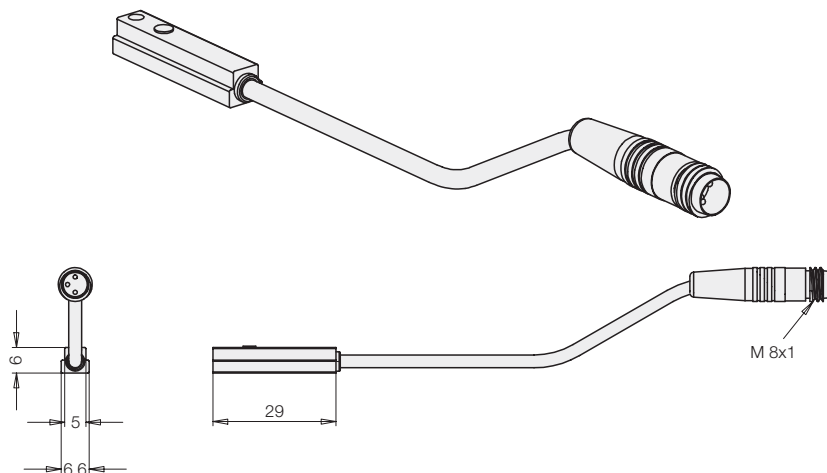

Connecting cable with coupling

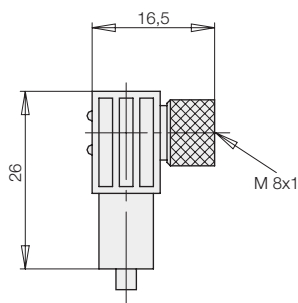

Connecting scheme

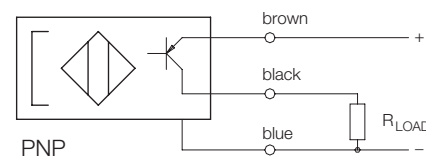

Technical characteristics

	Electronic magnetic sensor	Connecting cable with coupling
Cylinder body material	PA 6	
Voltage	10 – 30 V DC	10 – 30 V DC
Residual ripple	max. 10%	
Current load I_{LOAD}	200 mA	
Current consumption	≤ 25 mA	
Protected against short circuits	yes	
Protection against reverse battery	installed	
Switching hysteresis	typ. 1.5 mm	
Protection as per IEC 529	IP 65	IP 67
Environmental temperature	-25°C up to +70°C	-25°C up to +90°C
Plug connection	M8 plug	M8 coupling
Function display	LED (yellow)	LED (yellow)
Voltage	no	LED (green)
Cable, length of cable	0.26 m	PUR, 5 m
Output	pnp	
Part-no. (1 off)	3829-147	3829-099

Further accessories

see data sheet B 1.555

- Pin-and-socket connector
- Y-distributor
- Reversing plug
- Voltage regulator