

Threaded-Coupling Elements max. operating pressure 500 bar



Application

Compared to other coupling elements the threaded coupling elements are very compact devices.

If the slide movement of the workpiece carrier is to be used or if a fixture is to be connected to the base plate without lines, the threaded nipple and the coupling mechanisms can be directly screwed into the parts which are to be connected. The coupling mechanisms have the advantage that they are flush-faced in uncoupled mode.

Flange-type housings are available to simplify the manufacture of the fixture mounting hole contours. In cramped conditions it is possible to make and install the flange-type housing retrospectively.

The fixture bodies which are to take up the coupling parts have to be guided 2-3 mm in a parallel motion before they are coupled.

The axial forces which arise during the pressure build-up in coupled mode (see diagram) have to be absorbed outside the coupling parts.

The threaded nipples, which are installed into the tank lines, are equipped with a pre-loaded valve (VSV). The pre-loaded valve limits a possible pressure build-up in the return line to approx. 5 bar by causing internal leakage in the hydraulic clamping elements. In coupled mode the pre-loaded valve is not effective.

Manifold-mounting hole

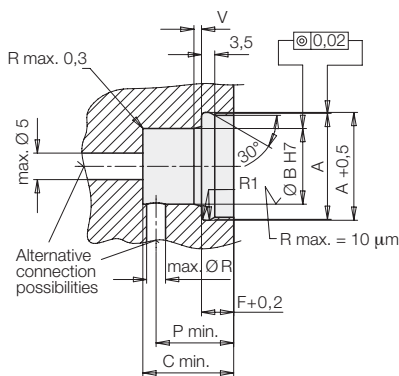

Threaded nipple

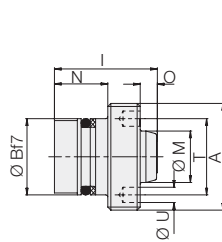

Coupling mechanism

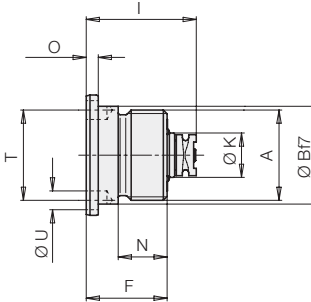

Manifold-mounting hole

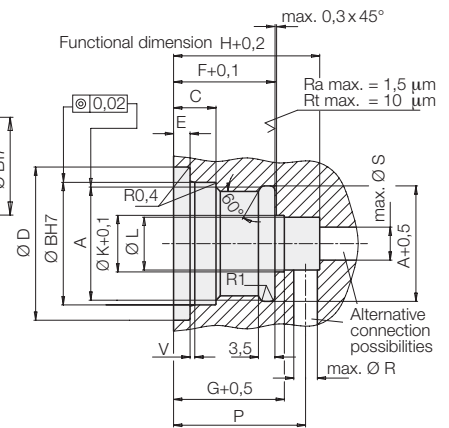

Element		Coupling mechanism	Threaded nipple	Threaded nipple with VSV	Coupling mechanism	Threaded nipple with VSV	Threaded nipple
NW		3	3	3	5	5	5
A	[mm]	M20 x 1.5	M24 x 1.5	M24 x 1.5	M24 x 1.5	M28 x 1	M28 x 1
Ø B	[mm]	22	20	20	26	20	20
C	[mm]	3.5	27	30	9	30	24
Ø D	[mm]	-	-	-	32.5	-	-
E	[mm]	-	-	-	3.5	-	-
F	[mm]	21.5	10	10	21.5	8.5	8.5
G	[mm]	23.5	-	-	23.5	-	-
H	[mm]	31	-	-	31	-	-
I	[mm]	29.3	29.5	34	29.3	32	27
Ø K	[mm]	12	-	-	12	-	-
Ø L	[mm]	11.2	-	-	11.2	-	-
Ø M	[mm]	-	9.8	9.8	-	13.5	13.5
N	[mm]	18.5	15	19.5	13	19.5	14
O	[mm]	-	4.5	4.5	3.2	4.5	4.5
P	[mm]	28	21	25	28	20.5	20.5
Ø R	[mm]	5	5	5	5	5	5
Ø S	[mm]	7	7	7	7	7	7
T	[mm]	16	17	17	24	20	20
Ø U	[mm]	3	3.5	3.5	5	4.3	4.3
V		-	2 x 15°	2 x 15°	1 x 15°	2 x 15°	2 x 15°
max. positioning tolerance							
axial	[mm]	+ 0.5	+ 0.5	+ 0.5	+ 0.5	+ 0.5	+ 0.5
radial	[mm]	± 0.1	± 0.1	± 0.1	± 0.2	± 0.2	± 0.2
Angular deviation		± 1°	± 1°	± 1°	± 1°	± 1°	± 1°
Coupling stroke	[mm]	4.5	4.5	4.5	4.5	4.5	4.5
Seating torque	[Nm]	37	40	40	40	45	45
Part-no.							
coupling against system press.		0460-725	0460-727	-	0460-735	-	0460-638
depressurised coupling		0460-730	0460-731	0460-728	0460-736	0460-637	0460-740
Special steel version							
depressurised coupling		-	-	-	0460-763	-	0460-765

Depending on the version the coupling elements can either be coupled in energized or in deenergized mode only.

The operating mode depends on the type of sealing elements which are used and can be taken from the table above.

The max. positioning tolerances in axial and radial direction are indicated in the above table.

To transmit compressed air and vacuum use only the coupling elements for "depressurised coupling".

The sealing areas at the side of the coupling elements have to be cleaned before coupling, to ensure the connection in coupled mode. We recommend to wash the elements and finally clean them with compressed air. Protection covers should be used as far as possible.

Previous cleaning of the even sealing areas is possible by means of rubber wipers.



Technical data

Coupling force

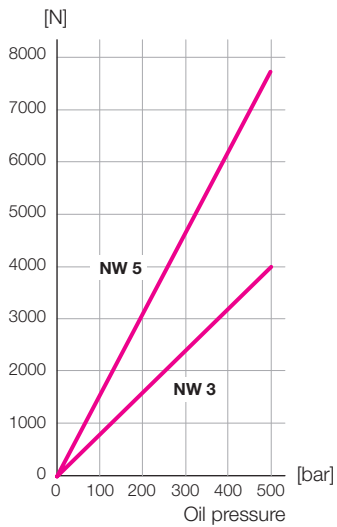

Δp -Q characteristic line for cinematic viscosity

from $53 \times 10^{-6} \text{ m}^2/\text{s}$ (HLP 22 at 20 °C)

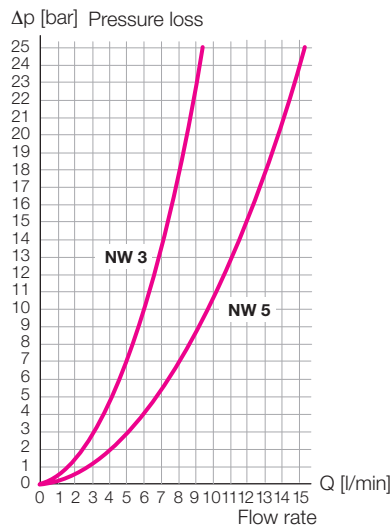

Accessory flange-type housing

Mounting dimensions

If it is not required that the housing is flush fitting with the pallet, the diam. $D + 0.2$ can be omitted.

The depth dimensions are then shortened by dimension F.

Usable for	0460-735	0460-725
	0460-736	0460-730
A [mm]	43	30
B [mm]	23	20
$\varnothing C H7$ [mm]	32	25
$\varnothing D + 0,2$ [mm]	65	50
E [mm]	38	38
F + 0,05 [mm]	15	12
G min. [mm]	35	34
H [mm]	12	10
K [mm]	18	16
L [mm]	M 8	M 6
M	$3 \times 15^\circ$	$3 \times 15^\circ$
$\varnothing N \text{ max.}$ [mm]	6	5
$\varnothing O$ [mm]	7	7
R [mm]	60	42
S [mm]	40	32

Part-no. (housing) **0460-654** **0460-655**

Seal kits for

connecting housing **0131-994** **0131-995**

Flange-type housing

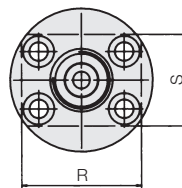
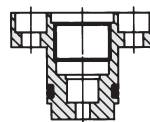

Manifold-mounting hole

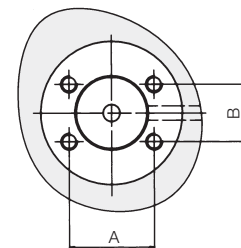
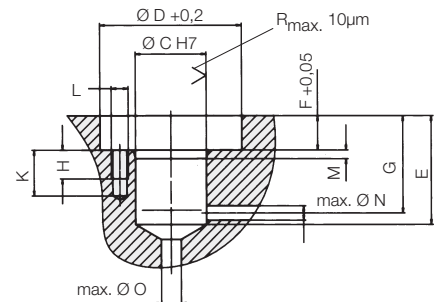

In cramped installation conditions the housing can be machined according to dimensions R and S.