

**Intensifier**  
**4 pressure stages**  
**max. operating pressure 500 bar**



**Description**

This pneumatic-hydraulic intensifier can be used as a pressure generator where live cables are not possible or suitable, e.g. in hazardous surroundings. Only single-acting cylinders can be connected. The cylinder volume should utilise the working only up to 60-70% so as to have some reserve left. When designing fixtures, some features of the air intensifier should be taken into account:

**1. Extend cylinder**

Air intensifiers are liable to release the effective oil volume very quickly within 1 second. The oil speed depends only on the volume flow of the compressed air. This may cause malfunctions in clamping elements where the maximum volume flow is limited (swing clamps, work supports). In those cases a flow control valve must be provided on the oil side.

**2. Pressure build-up**

After extending the cylinders, pressure build-up is relatively slow, according to the nominal bore of the pneumatic piping and air pressure. At 6 bar the sextuple working volume must be fed, which takes approx. 3 seconds

**3. Pressure release**

For this purpose, the air volume accumulated must first be reduced to a residual pressure below 0.2 bar, before the connected hydraulic cylinders retract. The high-speed vent valve available as an accessory allows for a pressure release time of approx. 2 sec. at an initial pressure of 6 bar.

**4. Pressure adjustment**

The hydraulic operating pressure can only be adjusted by means of a pressure reducing valve on the pneumatic side. We recommend our service unit **part-no. 9511-005**.

Important note: The maximum operating pressure on the hydraulic side is determined by the component having the smallest admissible operating pressure.

The pneumatic adjustment must be checked by a pressure gauge located on the hydraulic side.

**5. Replenishment**

Any minor leak losses are compensated by replenishing out of the oil tank. This requires a well vented system and an oil filler screw slightly opened.

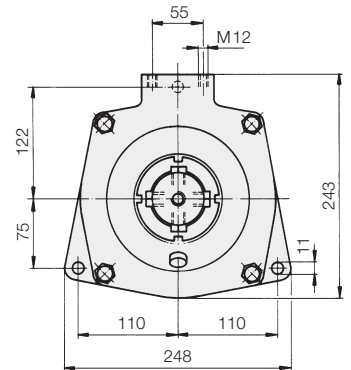
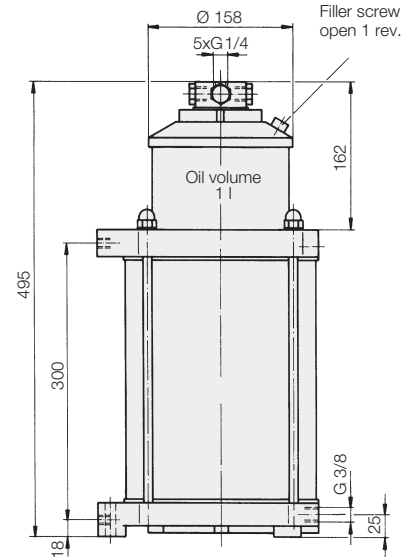
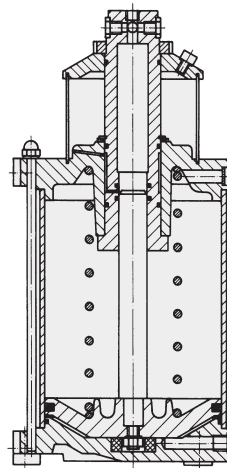

Max. air consumption per stroke at 6 bar	approx. 28.3 l
Viscosity range	(4...1000) 10 <sup>-6</sup> m <sup>2</sup> /s
Recommended viscosity class	ISO VG 22 as per DIN 51519
Recommended hydraulic oil	HLP 22 as per 51524
Weight	22 kg
Mounting position	vertical or horizontal on mounting surface

Intensification ratio	Oil pressure [bar] at 6 par air pressure		Max. air pressure [bar]	Max. oil pressure [bar]	Work volume [cm <sup>3</sup> ]	Part-no.
	min.	max.				
82.64:1	462	480	6.3	505	57	<b>8772-101</b>
64 :1	358	372	8	500	73	<b>8773-101</b>
39.06:1	218	227	8	305	120	<b>8774-101</b>
25 :1	140	145	8	195	188	<b>8775-101</b>

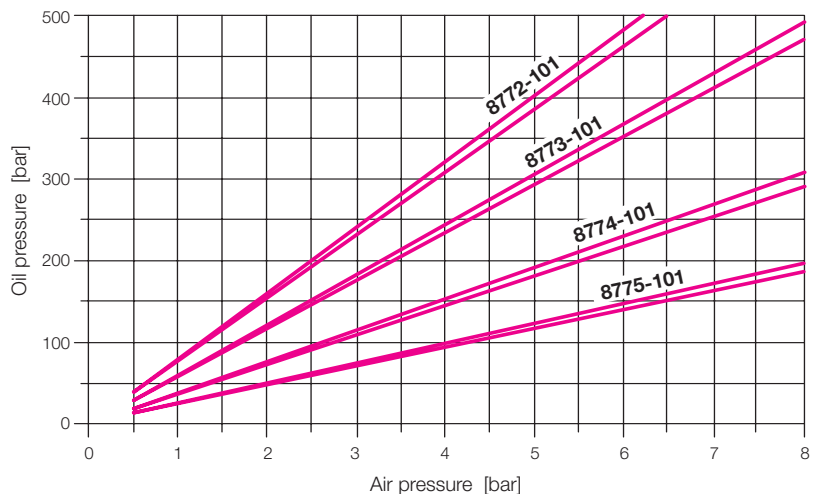



# ROEMHELD

## Start up

The air intensifiers are delivered without oil. After connecting the cylinders, the oil reservoir can be filled.

## Air Bleeding

Complete bleeding is particularly important because of the limited working volume of the air intensifier. Bleeding is facilitated by first arranging the air intensifier somewhat below the cylinder level, i.e. the pipes rise slightly towards the cylinders. Loosen the most distant union nut of the fitting at the cylinder. Then blow cautiously compressed air into the filling port of the oil reservoir. The overpressure (max. 2 bar!) generated in the reservoir displaces the hydraulic oil in the pump body and into the piping system, thus expelling the air through the unfastened swivel nut.

When only bubble-free oil comes out, first fasten swivel nut and then shut off compressed air. If necessary repeat this at the other cylinder connections. Finally, the oil reservoir has to be filled up again.

During operation, the hydraulic connection of the air intensifier should lie above the cylinder level. This is to avoid that, during prolonged standstill periods in depressurised condition, a partial vacuum is produced in the system that causes the intake of air through the cylinder seals.

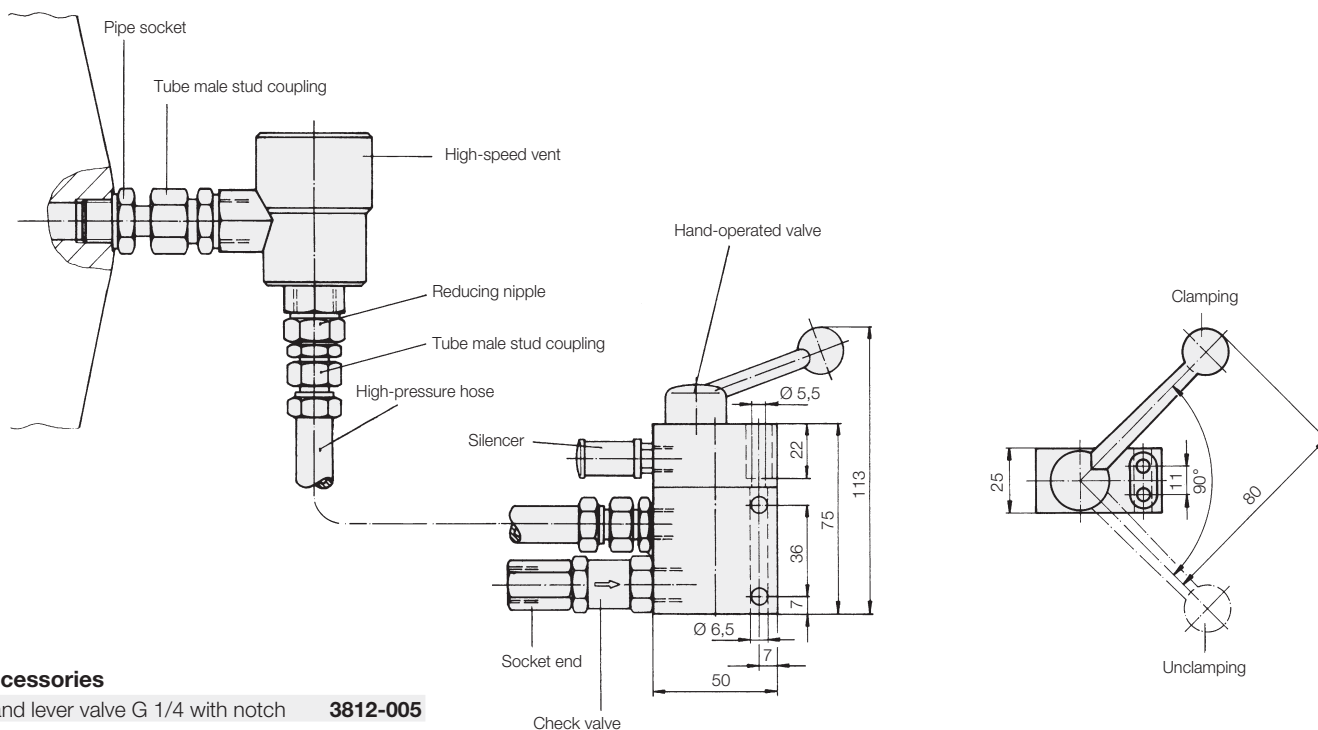
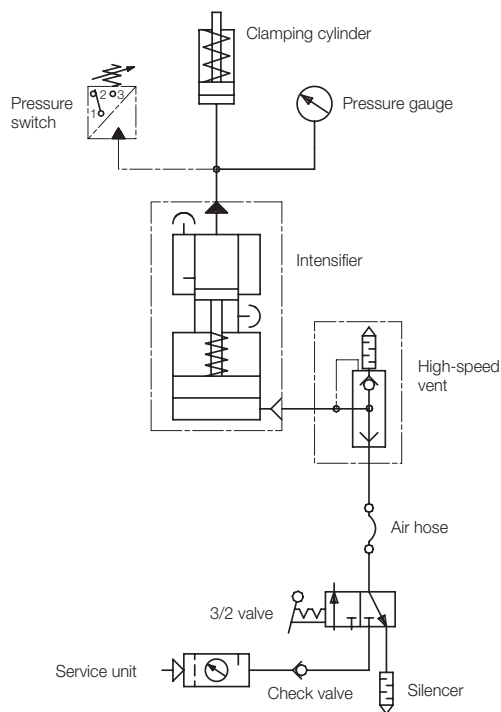

## Accessories

Hand lever valve G 1/4 with notch	<b>3812-005</b>
Sound absorber for hand lever valve	<b>3887-015</b>
Foot-actuated valve G 1/4 with notch incl. safety cover	<b>0381-206</b>
High-speed vent valve G 3/8	<b>3812-008</b>
High-pressure hose	<b>9320-6XX</b>
Tube male stud coupling D 8 L	<b>9208-003</b>
Reducing nipple G 1/4 inside, G 3/8 outside	<b>3890-064</b>
Tube male stud coupling D 12 L	<b>9212-030</b>
Pipe socket DC 12 L	<b>9212-032</b>
Check valve	<b>3812-009</b>
Socket end G 1/4 – G 1/4	<b>3890-077</b>
Service unit see figure	<b>9511-005</b>
Pressure gauge 600 bar	<b>9846-000</b>
Pressure gauge union	<b>9208-040</b>

Service unit  
Part-no. 9511-005

