

Hydraulic Intensifier intensification ratio 1.5 to 7.5, max. operating pressure 500 bar

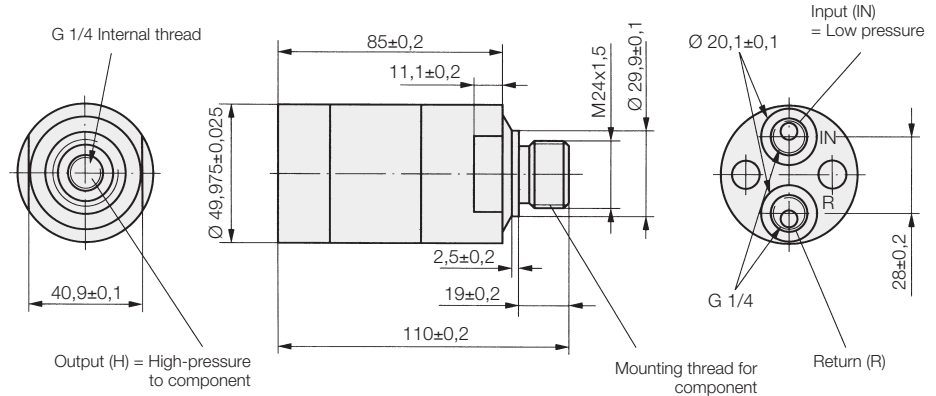

Application

The hydraulic intensifier converts a hydraulic pressure on the primary side (input) into a higher pressure on the secondary side (output).

This enables the use of the comparatively low pressure of machine tool hydraulics to pressurise a hydraulic cylinder with a correspondingly increased intensification ratio.

Description

The construction of the hydraulic intensifier corresponds to the principle of pressurising areas of different sizes. Regulation of the high pressure at the secondary side is made by regulation of the low pressure at the primary side and is directly proportional.

First the intensifier delivers a high flow rate at a low pressure (displacement of the cylinders), with increasing counterpressure the intensifier switches automatically to pressure intensification. For unclamping the cylinder is directly controlled with the low-pressure of the primary side (see example).

Operating conditions, tolerances and other data see data sheet A 0.100.

Function

The oil is supplied through input **IN** via the check valves **RV1**, **RV2** and **DV** to the high-pressure output **H** and thereby to the cylinders. In this phase the intensifier is in rapid function. According to the intensification **i** the max. flow rate can be up to 10 l/min. With increasing pressure in the cylinder the oscillating pump unit **OP** (pulsation) automatically functions. If the adjusted high-pressure is obtained, pulsation of the intensifier is stopped.

Pulsation continues in case of dynamic application. Max. frequency of pulsation is 30 Hz. To retract the cylinder, the internal check valve **DV** is controlled via port **R** and thereby free return through the intensifier is guaranteed.

Important notes

The hydraulic oil must be perfectly filtered with particles not larger than nominally 10 µm. We offer therefore filter units (see data sheet F 9.500), which can be directly integrated into the tubing at the low-pressure side.

If the intensifier will be used on uncoupled systems (no connection to the pressure generator) a pilot-controlled check valve should be mounted at the high-pressure side (consider min. control pressure for opening!).

Pilot-operated check valve, see accessories page 2.

When designing an installation, pay attention that there can be leakage between the ports **IN** and **R** of the high-pressure intensifier.

Leakage rate approx. 50 cm³/min

When using the intensifier in uncoupled systems there will be a pressure increase in the unclamping line due to the leakage. – Please contact us!

Example: Hydraulic circuit diagram

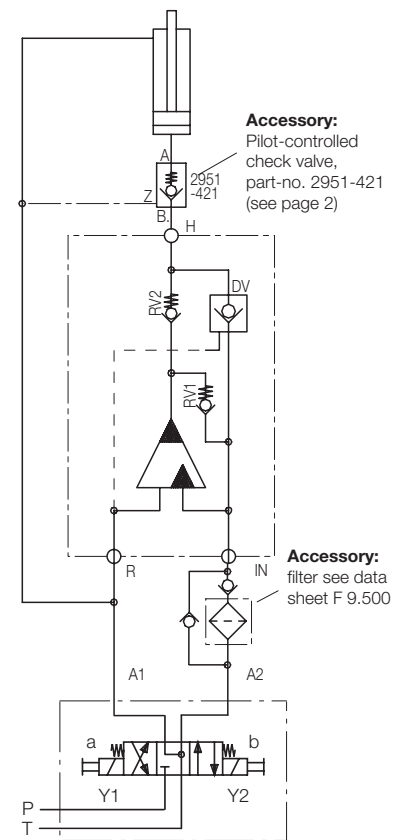

| Intensification i | 1.5 | 2.0 | 3.2 | 4.0 | 5.0 |
|--|-----------------|-----------------|-----------------|-----------------|-----------------|
| Max. flow rate, Low-pressure side Q_{IN} [l/min] | 8 | 8 | 15 | 14 | 14 |
| Max. flow rate*, High-pressure side Q_H [l/min] | 1 | 0.8 | 2.5 | 2.0 | 1.6 |
| Max. operating pressure Low-pressure side P_{IN} [bar] | 200 | 200 | 155 | 125 | 100 |
| Max. operating pressure High-pressure side P_H [bar] | 300 | 400 | 500 | 500 | 500 |
| Weight [kg] | 1.0 | 1.0 | 1.0 | 1.0 | 1.0 |
| Part-no. | 8755-015 | 8755-020 | 8755-032 | 8755-040 | 8755-050 |

* With increasing counter pressure on the high-pressure side the flow rate will drop until zero.

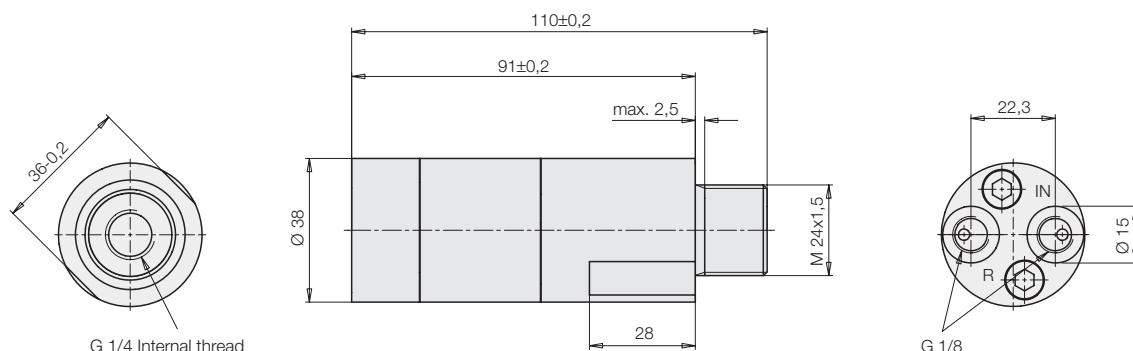

| Intensification <i>i</i> | 3.3 | 4.0 | 4.8 | 6.2 | 7.5 |
|---|-----------------|-----------------|-----------------|-----------------|-----------------|
| Max. flow rate, Low-pressure side Q_{IN} [l/min] | 8 | 8 | 8 | 8 | 8 |
| Max. flow rate, High-pressure side Q_H [l/min] | 0.5 | 0.4 | 0.4 | 0.3 | 0.3 |
| Max. operating pressure Low-pressure side P_{IN} [bar] | 151 | 125 | 104 | 80 | 66 |
| Max. operating pressure High-pressure side P_H [bar] | 500 | 500 | 500 | 500 | 500 |
| Weight [kg] | 1.0 | 1.0 | 1.0 | 1.0 | 1,0 |
| Part-no. | 8755-132 | 8755-140 | 8755-148 | 8755-162 | 8755-175 |

Accessories

Pilot-operated check valve, pilot-controlled

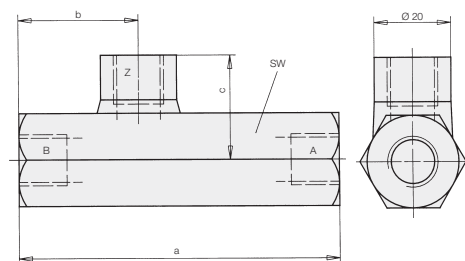
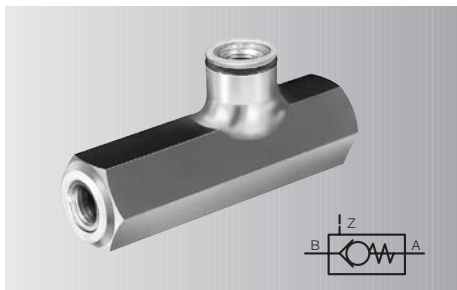

| | |
|-----------------------------|--|
| Configuration | spring-loaded ball-type poppet valve, leakage-free tubes |
| Type of mounting | Tube |
| Port size A,B | G1/2 |
| Control port Z | G1/4 |
| Control volume | [cm ³] 0.40 |
| Control pressure $p_Z \geq$ | [bar] $0.086 p_A + 13$ |
| Max. operating press. | [bar] 500 |
| Flow max. | [l/min] 55 |
| a | [mm] 100 |
| b | [mm] 36.5 |
| c | [mm] 31 |
| SW | [mm] 32 |
| Weight | [kg] 0.6 |
| Part-no. | 2951-421 |

Description

These check valves are designed in accordance with DIN ISO 1219. According to this definition this type of valve is a locking valve. The flow B → A is free. The flow from A → B is locked, but it can be hydraulically unlocked by pressurising control port Z.

Further pilot-operated check valves see page C 2.9511/2.

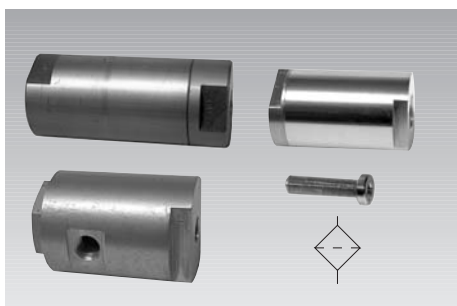

Hydraulic filter see data sheet F 9.500.