

Threaded-Body Work Supports max. operating pressure 500 bar



General technical characteristics

Plunger Ø	[mm]	16
Stroke	[mm]	8 (15)
Adm. support force at 500 bar		
194X-00X	[kN]	6.5
194X-01X	[kN]	9.5
Recom. minimum oil pressure [bar]		100
Seating torque	[Nm]	60
Weight	[kg]	ca. 0.25

Mounting dimensions, accessories and application examples see reverse page

Admissible load F as function of the operating pressure p

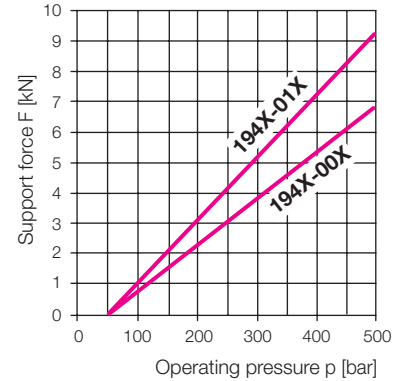

Application

Hydraulic work supports are used to provide a self-adjusting rest for the workpiece during the machining operations. They compensate the workpiece surface irregularities, also deflection and vibration under machining loads. Two sizes are available. The threaded-body design of the elements allows direct installation in clamping fixtures, in horizontal or vertical mounting position, and thereby a space-saving arrangement. Hydraulic oil is fed through drilled channels in the fixture body. Hydraulic locking is made together with hydraulic clamping of the workpiece, or independently.

There are three variations of plunger actuation:

- 1. Spring advanced;** plunger extended in off-position
- 2. Air pressure advanced;** plunger retracted in off-position. The pneumatically-actuated plunger allows precise setting of the plunger contact force by means of a pressure reducing valve.
- 3. Hydraulic pressure and spring advanced;** plunger retracted in off-position. It moves forward with a light spring force against the workpiece, when hydraulic pressure is applied.

Combination possibilities

The work supports 194X-01X can be combined with the swing clamps as per data sheet B 1.891. (Example see reverse page).

Important notes

Operating conditions, tolerances and other data see data sheet A 0.100.

Contact by spring force



a	[mm]	80.5	90.5
b	[mm]	79	89
c	[mm]	54	64
Spring force min./max.	[N]	8/13	8/13
Part-no.		1940-000	1940-010

Contact by air pressure



a	[mm]	84	94
b	[mm]	72.5	82.5
c	[mm]	71	81
d	[mm]	54	64
Spring force min./max.	[N]	20/30	20/30
Plunger contact force at 1 bar air pressure (deduct spring force if necessary)	[N]	20	20
Part-no.		1941-000	1941-010

Contact by oil pressure



Stroke	[mm]	8	15	8	15
a	[mm]	72.5	79.5	82.5	89.5
b	[mm]	71	78	81	88
c	[mm]	54	61	64	71
Spring force min./max.	[N]	10/23	10/23	10/23	10/23
Max. oil flow rate	[cm ³ /s]	25	25	25	25
Part-no. Stroke 8		1942-000	1942-010		
Stroke 15		1942-005	1942-015		

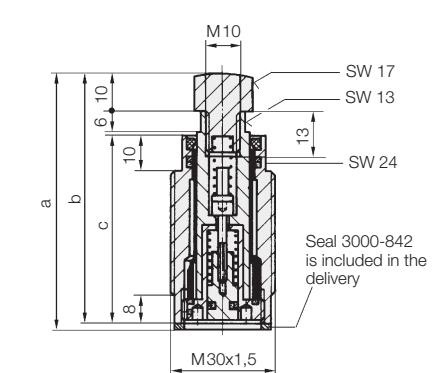
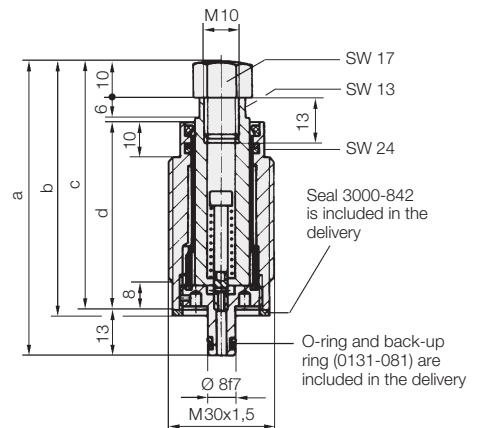
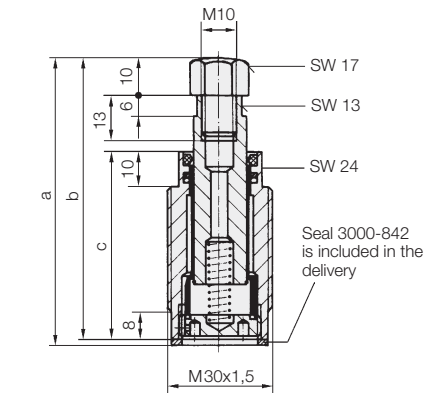



ROEMHELD

Installation dimensions 1940-0X0/1942-0X0

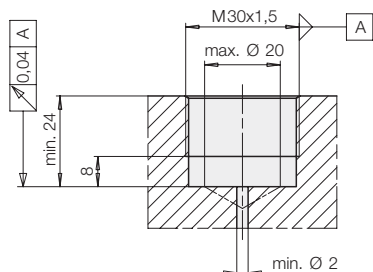

Installation dimensions 1941-0X0

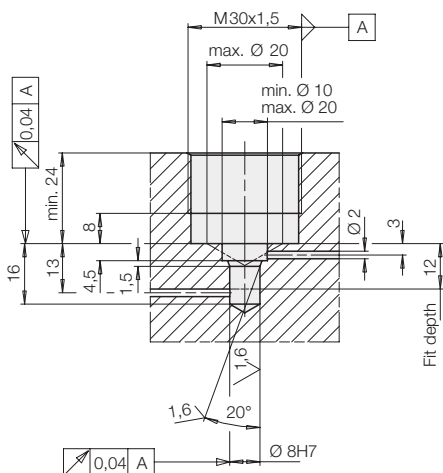

Accessories

Mounting body **part-no. 3467-086** as per data sheet B 1.460 or

body with pneumatic connection

Part-no. 3467-112

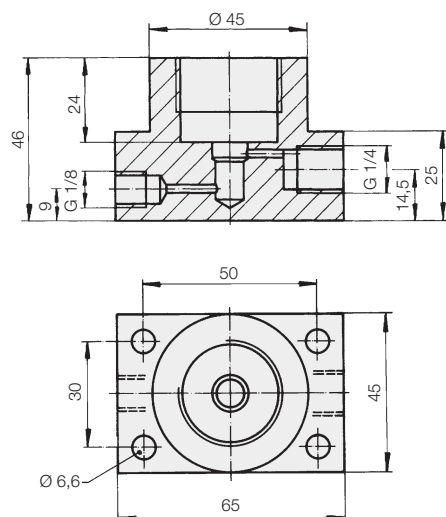

Installation example

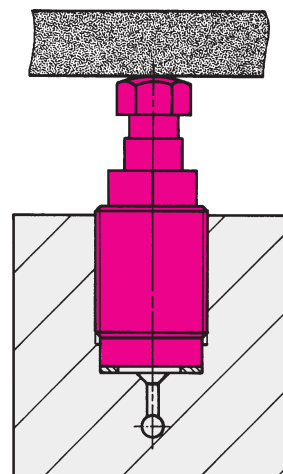

Combination possibility

Threaded-body work support with threaded-body swing clamps as per data sheet B 1.891

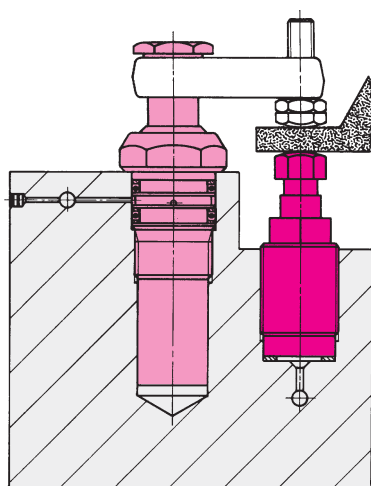

Support and clamping forces have to be adapted to each other, so that there will be sufficient force reserve available for the threaded-body work support to absorb the machining forces.

Thumb rule: Support force $\geq 2 \times$ opposing force

The required minimum pressure is 200 bar.

The diagram below shows the graphs of the clamping and support forces for the 2 possible combinations.

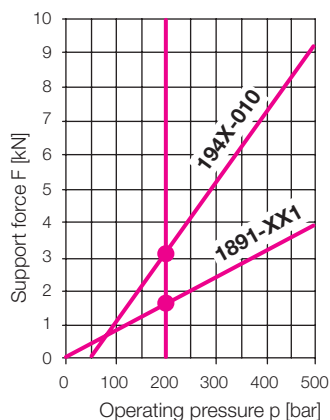

Example

Swing clamp 1891-XX1 clamps against threaded-body work support 194X-010. Operating pressure 200 bar.

Support force 3 kN

Clamping force -1.5 kN

1.5 kN = possible opposing force