

Spring Clamping Cylinder

pulling, with hydraulic return

max. operating pressure see unclamping pressure, $h = 1 \text{ mm}$

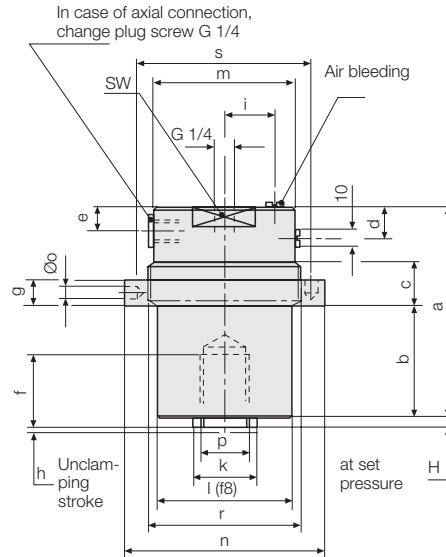

Adjustment of clamping force, clamping and unclamping

1. Apply set pressure to spring clamping cylinder.
2. Adjust clamping position to be free from play by means of ring nut.
3. Secure ring nut against torsion. If necessary, secure cylinder against sliding. See application examples.
4. For clamping, reduce set pressure.
5. For unclamping, apply unclamping pressure.
6. Check play of clamping point after approx. 1000 load changes at set pressure. If necessary, retighten ring nut and secure again.

Application

Especially suitable for long-term clamping of movable machine parts, tools, fixtures, pallets, and workpieces in any position. Clamping mechanically by hydraulically adjustable Belleville spring assembly. Unclamping hydraulically.

Description

Belleville spring assembly installed in hydraulic cylinder. Housing made of tempering steel. Piston in one-piece design, hardened and ground. Ring nut for support and adjustment free from play. Piston rod with interior thread.

Advantages

- large choice of clamping forces
- low-friction Belleville springs placed between hardened and ground thrust washers
- piston secured against rotation
- oil ports radial and axial

Important notes

For other clamping forces, unclamping stroke $> 1 \text{ mm}$, more than 1 load change per minute, aggressive fluids, and temperatures below -15°C or above 60°C , please consult us. Unclamping stroke limitation and special design upon request. Operating conditions, tolerances and other data see data sheet A 0.100.

Power units see catalogue section "D".

Clamping force	[kN]	16	25	40	63	100
Set pressure	[bar]	165	165	185	215	250
Unclamping press., $h = 0.5 \text{ mm}$	[bar]	210	200	210	235	275
Unclamping press., $h = 1 \text{ mm}$	[bar]	255	235	235	255	300
Oil requirement/1 mm stroke	[cm ³]	1.3	2.0	2.9	3.9	5.0
a	[mm]	95	105	120	132	147
b	[mm]	45	50	60	70	80
c	[mm]	20	20	25	25	30
d	[mm]	22	22	22	23	23
e	[mm]	11	11	11	12	12
f	[mm]	24	30	36	45	45
g	[mm]	13	14	14	16	16
i (f8)	[mm]	18	20.5	27	32	36
k	[mm]	20	25	30	40	40
l	[mm]	55	65	75	85	95
m	[mm]	55	65	75	89	99
n	[mm]	85	95	110	125	140
o	[mm]	6	8	8	8	8
p	[mm]	M14x1.5	M18x1.5	M22x1.5	M30x1.5	M30x1.5
r	[mm]	M58x1.5	M68x1.5	M78x1.5	M92x1.5	M102x1.5
H	[mm]	4	4	4	6	6
SW	[mm]	50	60	70	80	90
s	[mm]	72	82	94	109	121
Weight	[kg]	1.8	2.6	3.9	5.7	7.8
Part-no.		1401-010	1402-010	1403-010	1404-010	1405-010

Other sizes upon request

