

## Low-Block Clamping Cylinder

single acting with spring return, max. operating pressure 500 bar

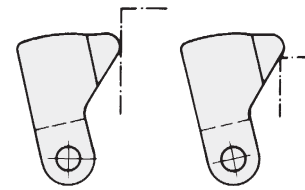
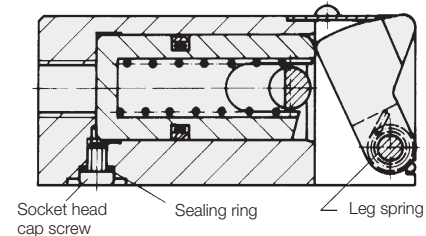
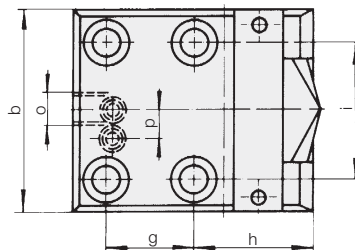
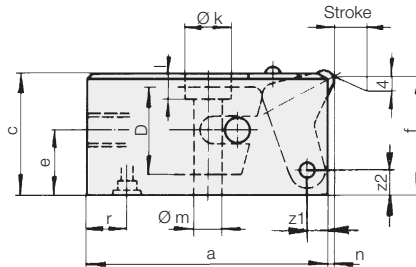
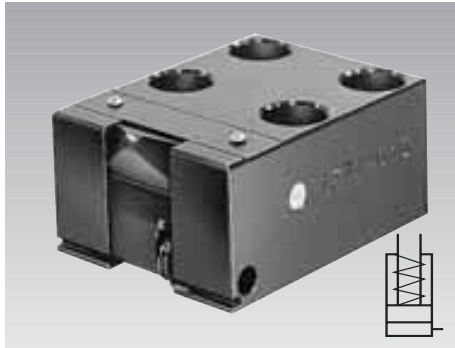

Clamping possibilities

### Description

The preferred application of low-block clamping cylinders are clamping situations where workholding from above is not possible or necessary. The low-clamping effect is caused by the downward motion of the clamping point. The average horizontal force component is 94% and the vertical force component is approx. 34% of the nominal clamping force. The high vertical force guarantees that the workpieces are safely held down. The clamping lever is continuously hardened so that the shape of the clamping point can be adapted to the workpiece by regrinding. A clamping lever with female thread for mounting of contact bolts can be delivered as accessory.

### Material

Cylinder body material: Steel, black oxide  
Clamping lever: 58 Cr V4, Hrc 54-58

### Important notes

Cylinders have to be protected against direct influences of aggressive cutting lubricants and coolants.  
Operating conditions, tolerances and other data see data sheet A 0.100.

### Application example



Piston Ø D	[mm]	16	25	36
Stroke	[mm]	8	10	10
Clamping force at	100 bar [kN]	1.7	4	8
	500 bar [kN]	8.5	20	40
Oil volume per 10 mm stroke	[cm <sup>3</sup> ]	2	4.9	10.2
a	[mm]	68	90	96
b	[mm]	50	60	80
c	[mm]	32	40	50
d max.	[mm]	6	6	6
e	[mm]	19	23	27
f	[mm]	31	39	49
g	[mm]	27	38	38
h	[mm]	32	42	46
i	[mm]	32	40	56
Ø k	[mm]	13.5	15	18
l	[mm]	8.5	9	11
Ø m	[mm]	8.5	9	11
n	[mm]	2	-	2
o		G 1/4	G 1/4	G 1/4
p	[mm]	-	-	14
r	[mm]	13	14	16
z1	[mm]	5.5	6	8
z2	[mm]	6	9	11
Weight	[kg]	0.9	1.15	2.1

<b>Part-no.</b>	<b>1371-010</b>	<b>1373-010</b>	<b>1374-010</b>
<b>Accessories</b>			
Screw plug G 1/4	<b>3610-006</b>	<b>3610-006</b>	<b>3610-006</b>
O-ring 10 x 2	<b>3000-347</b>	<b>3000-347</b>	<b>3000-347</b>
Spare seal ring	<b>3000-536</b>	<b>3000-536</b>	<b>3000-546</b>
Clamping lever, one piece	<b>3542-080</b>	<b>3542-081</b>	<b>3542-082</b>
Leg spring, spare part	<b>3715-104</b>	<b>3715-104</b>	<b>3716-109</b>

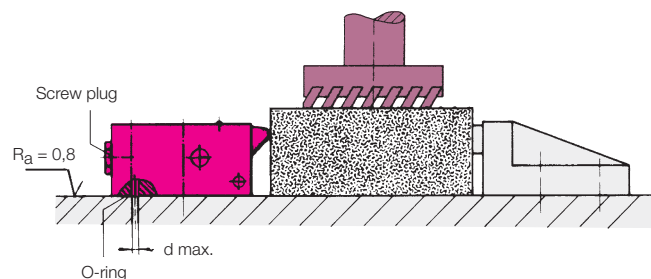

The hydraulic oil can optionally be supplied through tubes or drilled channels in the fixture body; 4 fixing screws are required.